

# UB3100-3300

---

Upblast Roof Exhauster



MoffittCorp.com | (800) 474-3267  
1351 13th Ave S. Suite 130 Jacksonville Beach, FL 32250

 **MOFFITT CORPORATION**  
NATURAL VENTILATION SOLUTIONS

## UB3100-3300 Table of Contents

UB3100-3300 Table of Contents .....	1
UB3100 – 3300 Upblast Roof Exhausters Product Details .....	2
UB3100 – 3300 Cut Sheet .....	3
UB3100 – 3300 Canted Insulated Roof Curb Submittal Data .....	4
UB3100 Direct Drive Upblast Roof Exhauster Performance Data .....	5
UB3100 Direct Drive Upblast Roof Exhauster Performance Data cont. ....	6
UB3300 Belt Drive Upblast Roof Exhauster Performance Data .....	7
UB3300 Belt Drive Upblast Roof Exhauster Performance Data cont. ....	8
Installation, Operation, and Maintenance Manual – Shipping, Handling, & Storage.....	9
Installation, Operation, and Maintenance Manual – Installation.....	10
Installation, Operation, and Maintenance Manual – Start-up & Maint. ....	11
Installation, Operation, and Maintenance Manual – Bearings.....	12
Installation, Operation, and Maintenance Manual – V-Belt.....	13
Installation, Operation, and Maintenance Manual – V-Belt cont.....	14
Installation, Operation, and Maintenance Manual – Motor .....	15
Installation, Operation, and Maintenance Manual – Motor - Warranty .....	16
UB3100 – UB3300 Series Safety Guard Basket.....	17
UB3100 – UB3300 Magnetic Damper Latch Installation Instructions .....	18
UB3100 Direct Drive Upblast Roof Exhauster Guide Specification.....	19
UB3100 Direct Drive Upblast Roof Exhauster Guide Specification cont.....	20
UB3300 Belt Drive Upblast Roof Exhauster Guide Specification .....	21
UB3300 Belt Drive Upblast Roof Exhauster Specification cont. ....	22

## UB3100 – 3300 Upblast Roof Exhausters Product Details

### STANDARD FEATURES

- Sizes: 24" – 120"
- CFM Range: 5,000 – 100,000 +
- Statically and Dynamically Balanced Aluminum Propeller
- All Galvanized Steel Construction
- Variable Pitch Drives Standard Through 3 HP
- Drives Sized for a Minimum 150% of Drive HP
- 1 Year Fan and Motor Warranty
- Removable Panel for Easy Damper Access
- Heavy Duty 200,000 Hour Rated Pillow Block Bearings
- Low Profile
- Integral Deep Spun Inlet
- Motor: Open Drip Proof
- Bird screen: ½" mesh, 19 ga. galvanized steel
- Complete Operation & Maintenance instructions & assembly drawings
- Units have been tested and rated in accordance with AMCA
- *Standards are guaranteed to perform as stated*

### OPTIONAL FEATURES

- Construction
  - Aluminum
  - Stainless Steel
- Propeller – FRP blades with cast aluminum hub
- Fiberglass damper doors
- Cushion Close - Steel Doors Only
- Magnetic latches
- Outlet Guard
- Safety basket guard
- Extended Lube Lines (Belt Drive)
- Roof Curbs
- Curb Cap Adaptor Max 4" + or -
- Access Door (Bolted)
- Disconnect Switch
- Coatings
  - Epoxy
  - Heresite
  - Coal Tar
- Finishes
  - Baked Powder Polyester
  - Baked Powder Fluoropolymer
  - Baked Powder Clear Coat
  - Clear Anodize
  - Integral Color Anodize

### APPLICATIONS

- Steel & Aluminum Plants
- Glass Plants
- Power Plants
- General Manufacturing Plants
- Chemical & Plastic Plants
- Mine Processing Plants
- Warehouses
- Pulp and Paper Plants
- Gypsum Wallboard

### PRODUCT DESCRIPTION

Moffitt Corporation, Inc. low silhouette axial upblast fans are designed for standard duty roof mount applications for exhausting building air to provide general ventilation of hot, stagnant areas. The series 3000 vertically exhausts the building air away from the roof and is available in direct and belt drive configurations. Sizes available range from 24" thru 120".

## UB3100 – 3300 Submittal Sheet

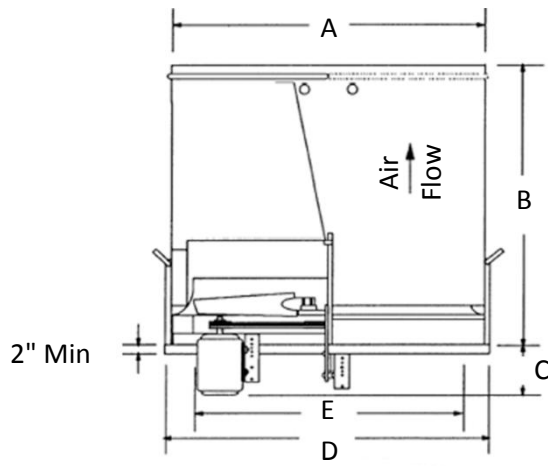

Model UB 3300- Belt Drive

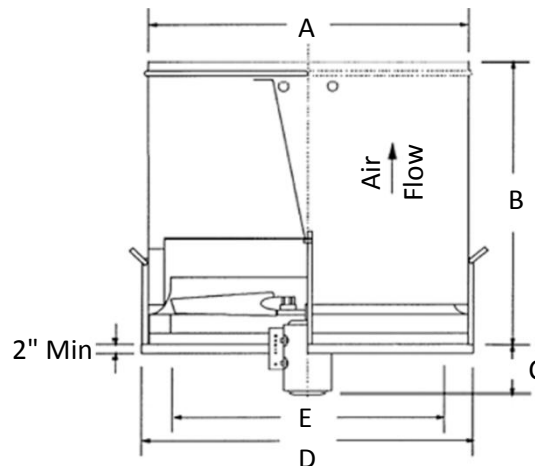

Model UB 3100- Direct Drive

SIZE	A O.D. Windband	B I.D. Curb Cap	C. MIN. I.D. Openin g	D I.D. Curb Cap	E Min. I.D. Openin g	STD PREFAB CURB O.D.	METAL GAUGES (1)			AVG. WT.
							WIND SHROUD	CURB CAP	FAN PANEL	
24	30	33	16	32 x 32	24 x 24	31 x 31				310
30	36	36	17	38 x 38	30 x 30	37 x 37				340
36	42	38	17	44 x 44	36 x 36	43 x 43		16	16	430
42	48	41	18	50 x 50	42 x 42	49 x 49	18			490
48	54	44	22	56 x 56	48 x 48	55 x 55				
54	60	47	22	62 x 62	54 x 54	61 x 61		14		840
60	66	50	22	68 x 68	60 x 60	67 x 67			14	1000
72	80	56	31	62 x 62	72 x 72	81 x 81		12	12	1550

1. All materials are G90 galvanized steel.
2. Translucent fiberglass damper doors are standard on 48", 54" and 60" models. (Available as an accessory on all other sizes.)
3. Propellers are available in 2, 3, 4 and 5 bladed, adjustable-pitch air-foil aluminum. (Fixed pitch, carbon steel, aluminum and FRP are also available.)
4. Single-pipe frames are used in 1/2hp through 5 hp/1160 RPM motors. Motors may extend below top of curbs (See "E" dim.).
5. Double-pipe frames are used on 5hp/870 RPM motors and larger. Curb caps are modified so that motors do not extend below top of curb. Add "E" and "D" dimensions for overall height.

All specifications are subject to change without notice unless approved in submittal by Moffitt Corporation, Inc.

## UB3100 – 3300 Canted Insulated Roof Curb Submittal Data

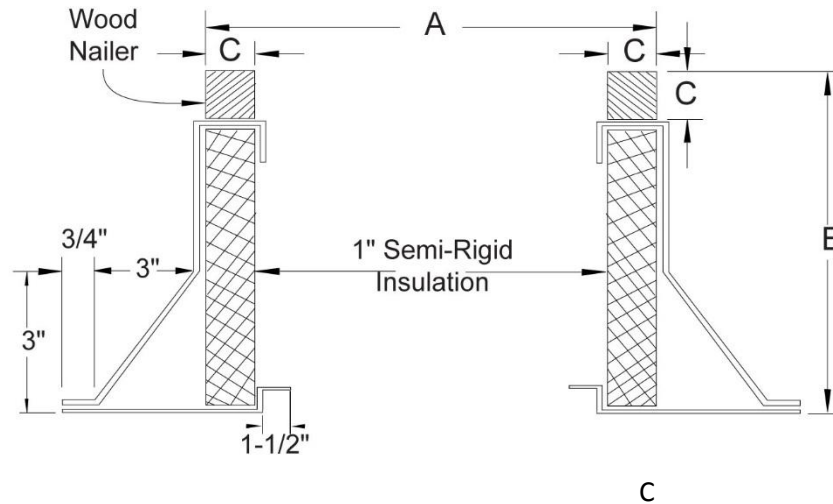

### OPTIONS:

1. Insulation retainers- solid or screen type.
2. Burglar bars- 1/2" diameters on 6" centers.
3. Finishes- baked or air-dried enamel or epoxy.
4. Heights: 8", 12", or 16".
5. Single pitch, double pitch, or flat style.
6. Damper Trap

Fan Size	"A" O.D. (Square) CURB/RF TYPE			"B" Curb Height	"C" Wood Nailer	Gauges	Weight
	Upblast Roof (1)	Model UB3700	Hooded Roof (2)				
24	31	28 ½	33 1/4	8"	1 ½ " Sq	18	39
30	37	34 ½	39 1/4				46
36	43	40 ½	45 1/4				54
42	49	46 ½	51 1/4				61
48	55	52 ½	57 1/4				68
54	61	58 ½	63 1/4				75
60	67	64 ½	69 1/4				82
72	81		83 1/4				99

1. Model- UB3100, UB3300
2. Model- HF8100, HF8300
3. Standard construction is shown. If special construction is required, note changes below and highlight.
4. G-90 galvanized welded steel construction.

All specifications are subject to change without notice unless approved in submittal by Moffitt Corporation, Inc.

## UB3100 Direct Drive Upblast Roof Exhauster Performance Data

Model UB3100	CFM @ Static Pressure					HP	RPM	Blades/Pi tch	Max. BHP	Sones @ 5
	0	1/8	1/4	3/8	1/2					
24	5900	5200	-	-	-	1/2	870	6	0.54	15
	6300	5400	-	-	-	1/2	1160	2	0.55	18
	6900	6300	5600	-	-	3/4	1160	3	0.81	22
	7400	6900	6400	5700	-	1	1160	6	1.10	23
	6600	6100	5500	4900	-	3/4	1750	2	0.82	30
	7500	7100	6500	5900	5200	1	1750	2	1.09	32
	9100	8500	7900	7300	6600	1-1/2	1750	2	1.63	36
	9500	9100	8700	8200	7800	2	1750	3	2.20	45
	11200	10800	10400	10000	9700	3	1750	4	3.30	54
30	10100	8700	-	-	-	3/4	870	4	0.83	21
	10600	9400	7900	-	-	1	870	6	1.11	22
	9800	8500	-	-	-	3/4	1160	2	0.81	27
	10900	9600	8300	-	-	1	1160	2	1.08	30
	12300	11300	10100	8600	-	1-1/2	1160	3	1.62	34
	13800	12900	11900	10700	-	2	1160	4	2.20	37
	10800	10000	9100	8200	9100	1-1/2	1750	2	1.65	44
	12800	12000	11200	10400	9500	2	1750	2	2.19	48
	15800	15000	14100	13200	12300	3	1750	2	3.30	58
	18600	17900	17200	16500	15600	5	1750	3	5.51	70
36	14200	12000	-	-	-	1	870	2	1.10	23
	15900	14300	12500	-	-	1-1/2	870	4	1.64	25
	17700	16200	14300	12400	-	2	870	4	2.17	33
	18900	17700	16300	14800	12700	3	870	6	3.24	36
	15700	14200	12400	-	-	1-1/2	1160	2	1.65	36
	17600	16000	14300	12200	-	2	1160	2	2.19	38
	20000	18400	16700	14900	12700	3	1160	2	3.32	42
	23000	22000	20700	19400	18000	5	1160	4	5.40	58
	17900	16700	15500	14300	13100	3	1750	2	3.26	75
	23700	22800	21700	20700	19500	5	1750	2	5.60	77
27400	26500	25300	24200	23100	7-1/2	1750	2	8.20	78	



Performance certified is for installation type A: Free inlet, Free outlet. Performance ratings do not include the effects of appurtenances in the airstream. The sound ratings shown are loudness values in fan sones at 5 ft. (1.5m) in a hemispherical free field calculated per AMCA Standard 301. Values shown are for free inlet fan sone levels. Speed (RPM) shown is nominal. Performance is based on actual speed of test.

Moffitt Corporation certifies that the Model UB3100 shown herein is licensed to bear the AMCA Seal. The ratings shown are based on tests and procedures performed in accordance with AMCA Publication 211 and AMCA Publication 311 and comply with the requirements of the AMCA Certified Ratings Program.

## UB3100 Direct Drive Upblast Roof Exhauster Performance Data cont.

Model UB3100	CFM @ Static Pressure					HP	RPM	Blades/ Pitch	Max. BHP	Sones @ 5
	0	1/8	1/4	3/8	1/2					
42	20400	17800	14000	-	-	1-1/2	870	2	1.60	28
	22800	19800	16700	-	-	2	870	2	2.24	31
	25400	23500	21400	19100	15900	3	870	4	3.27	33
	20800	18700	16200	13300	-	2	1160	2	2.23	42
	25200	23200	20900	18300	15000	3	1160	2	3.18	44
	30800	28300	26000	23600	21500	5	1160	2	5.58	50
	34600	33300	31800	30200	28500	7-1/2	1160	4	8.20	58
	32800	30000	30000	28500	-	7-1/2	1750	2	8.15	92
48	26200	22800	19700	-	-	2	870	2	2.17	33
	30800	27200	23200	18600	-	3	870	2	3.35	38
	36300	33500	30500	27000	21500	5	870	3	5.60	42
	40300	37700	34800	31800	27600	7-1/2	870	3	8.27	48
	27900	25000	22100	19700	-	3	1160	2	3.40	49
	35900	33500	31000	28900	24300	5	1160	2	5.55	57
	41800	39300	36500	33900	30700	7-1/2	1160	2	8.23	67
	45800	43000	40200	37400	34500	10	1160	2	11.10	69
54	35700	31600	26700	19400	-	3	870	2	3.28	47
	43900	39200	34600	29300	21900	5	870	2	5.55	54
	48900	45500	41900	38100	33300	7-1/2	870	3	8.32	59
	38500	35200	31800	28300	25000	5	1160	2	5.55	68
60	49200	46400	43000	39700	35700	7-1/2	1160	2	8.40	75
	55600	52500	49200	46400	41900	10	1160	2	11.20	77
72	57200	52600	47500	41800	35100	7-1/2	870	2	8.30	64
72	65500	59000	52000	44000	-	7-1/2	870	2	8.24	78



Performance certified is for installation type A: Free inlet, Free outlet. Performance ratings do not include the effects of appurtenances in the airstream. The sound ratings shown are loudness values in fan sones at 5 ft. (1.5m) in a hemispherical free field calculated per AMCA Standard 301. Values shown are for free inlet fan sone levels. Speed (RPM) shown is nominal. Performance is based on actual speed of test. Moffitt Corporation certifies that the Model UB3100 shown herein is licensed to bear the AMCA Seal. The ratings shown are based on tests and procedures performed in accordance with AMCA Publication 211 and AMCA Publication 311 and comply with the requirements of the AMCA Certified Ratings Program.

## UB3300 Belt Drive Upblast Roof Exhauster Performance Data

Model UB3100	CFM @ Static Pressure					HP	RPM	Blades/ Pitch	Max. BHP	Sones @ 5
	0	1/8	1/4	3/8	1/2					
24	7180	6500	5720	4800	-	3/4	1210	3	0.82	22
	7920	7300	6610	5880	-	1	1335	3	1.11	25
	9080	8550	7960	7340	6600	1-1/2	1525	3	1.65	32
	10000	9500	9000	8450	7900	2	1680	3	2.21	37
30	11000	9800	8400	-	-	1	960	3	1.15	25
	12500	11400	10300	9000	-	1-1/2	1090	3	1.69	33
	13700	12800	11700	10600	9400	2	1200	3	2.25	39
	15600	14800	13900	13000	1200	3	1370	3	3.35	46
36	13279	11086	-	-	-	1	700	3	1.26	21
	15081	13170	11062	-	-	1-1/2	795	3	1.85	27
	16978	15289	13502	11351	-	2	895	3	2.64	32
	19349	17872	16345	14714	12675	3	1020	3	3.91	37



Performance certified is for installation type A: Free inlet, Free outlet. Performance ratings do not include the effects of appurtenances in the airstream. The sound ratings shown are loudness values in fan sones at 5 ft. (1.5m) in a hemispherical free field calculated per AMCA Standard 301. Values shown are for free inlet fan sone levels. Speed (RPM) shown is nominal. Performance is based on actual speed of test.

Moffitt Corporation certifies that the Model UB3300 shown herein is licensed to bear the AMCA Seal. The ratings shown are based on tests and procedures performed in accordance with AMCA Publication 211 and AMCA Publication 311 and comply with the requirements of the AMCA Certified Ratings Program.



## UB3300 Belt Drive Upblast Roof Exhauster Performance Data cont.

42	19800	16800	-	-	-	1-1/2	640	3	1.68	25
	22100	19300	16000	-	-	2	710	3	2.30	30
	25000	22600	19800	16800	-	3	805	3	3.35	37
	29700	27600	25300	23000	20300	5	950	3	5.51	45
48	26300	22500	17600	-	-	2	575	3	2.31	25
	30200	26700	22700	17800	-	3	655	3	3.41	34
	35500	32500	29400	25800	21500	5	770	3	5.54	45
	40600	38000	35300	32600	29300	7-1/2	880	3	8.27	54
	44800	42500	40100	37500	34800	10	970	3	11.07	60
54	35000	30200	24200	-	-	3	545	3	3.39	28
	41200	36900	32500	27000	-	5	640	3	5.49	40
	47200	43700	39800	35700	30900	7-1/2	735	3	8.32	50
	51800	48500	45000	41300	37400	10	805	3	10.92	58
60	48200	42600	36000	27800	-	5	550	3	5.50	38
	55200	50300	45000	38800	-	7-1/2	630	3	8.27	51
	61000	56600	51900	46700	40700	10	695	3	11.10	60
72	61700	51900	40500	-	-	5	410	3	5.47	31
	70700	62300	53200	-	-	7-1/2	470	3	8.24	42
	78200	78800	52800	53300	-	10	520	3	11.15	50



Performance certified is for installation type A: Free inlet, Free outlet. Performance ratings do not include the effects of appurtenances in the airstream. The sound ratings shown are loudness values in fan sones at 5 ft. (1.5m) in a hemispherical free field calculated per AMCA Standard 301. Values shown are for free inlet fan sone levels. Speed (RPM) shown is nominal. Performance is based on actual speed of test.

Moffitt Corporation certifies that the Model UB3300 shown herein is licensed to bear the AMCA Seal. The ratings shown are based on tests and procedures performed in accordance with AMCA Publication 211 and AMCA Publication 311 and comply with the requirements of the AMCA Certified Ratings Program.

## **Installation, Operation, and Maintenance Manual – Shipping, Handling, & Storage**

### **INTRODUCTION:**

DO NOT INSTALL, USE OR OPERATE THIS EQUIPMENT UNTIL THIS MANUAL HAS BEEN READ AND UNDERSTOOD. READ AND SAVE THESE INSTRUCTIONS FOR FUTURE USE.

The purpose of this manual is to aid in the proper installation and operation of fans manufactured by Moffitt Corporation, Inc. These instructions are intended to supplement good general practices and are not intended to cover detailed instruction procedures, because of the wide variety and types of fans manufactured by Moffitt Corporation, Inc.

It is the responsibility of the purchaser to assure that the installation and maintenance of this equipment is handled by qualified personnel experienced in such work and equipment.

Contact your local representative should you need further information.

### **SHIPMENT AND RECEIVING:**

Prior to shipment, all fans have been thoroughly inspected and tested.

All equipment shipped from Moffitt Corporation, Inc. is skidded or crated to fully comply with trucking requirements. Inspect all shipments carefully for damage. THE RECEIVER MUST NOTE ANY DAMAGE ON THE CARRIER'S BILL OF LADING AND FILE A CLAIM IMMEDIATELY WITH THE FREIGHT COMPANY, IN THE CASE OF ANY DAMAGE. Keep a record of all equipment received, including inspection details and date of receipt, because of the possibility of partial shipments.

If you receive damaged goods, contact your Moffitt representative for repair or replacement service.

### **HANDLING**

Handle your equipment with caution. Some fans are provided with lifting lugs or holes for easy handling. Others must be handled using nylon straps which protect the fan's coating and housing. Spreader bars should be used when lifting large parts.

Fans should be lifted by using straps around the fan housing only. DO NOT LIFT FANS BY THE MOTOR BASE, PROP, WHEEL, OR FLANGES.

Roof ventilators should be lifted by using straps around the fan housing or base only. Spreader bars should also be used to avoid damage to stack caps or hoods. DO NOT LIFT ROOF VENTILATORS BY THE STACK CAP OR HOOD. On hooded units, disassemble the stack from hood when lifting. Upblast models may be lifted assembled.

### **STORAGE**

If fans are stored for any length of time, they should be stored in a clean, dry location to prevent rust and corrosion. Outdoor storage is not recommended. When outdoor storage is necessary, they should be protected from the elements as best as possible. Cover the fan inlet and outlet and keep motors dry and clean.

For extended storage (more than 3 months), motor shafts and bearings should be rotated monthly. If stored greater than 6 months, bearing grease in motor and fan should be purged and replaced with compatible grease.

Re-check belts for proper tension. Storage records should be kept to assure proper maintenance. The factory can advise warranty centers to provide motor and bearing service if needed.

## Installation, Operation, and Maintenance Manual – Installation

### INSTALLATION

Roof ventilators should always be mounted to a flat level, solid and rigid structure. Particular caution should be exercised when installing fans on metal buildings. Be sure wall or roofs are capable of supporting the fan(s). Walls/Roofs not supported correctly will cause vibration that could damage or injury.

Fans mounted off ground level should be rigidly mounted to a special platform and be placed as near as possible to, or over, a solid wall or column.

Supports for suspended fans must be cross braced for live load support to prevent side sway. Use guy wires to help secure roof units if excessively windy conditions prevail.

1. CAUTION! This fan contains rotating parts and requires special service. Appropriate safety precautions should be taken during installation, operation and maintenance.
2. WARNING! Do not install or operate this fan in environment or atmosphere where combustible or flammable materials, gasses or fumes are present, unless it was specifically designed and manufactured for use in that environment. Explosion or Fire can result. Explosive, corrosive, high temperature, etc. Conditions may require special construction, inspection and maintenance. It is necessary to observe the fan manufacturer's recommendations and limitation concerning the type of material to be handled by the fan and its application to special conditions.
3. When ventilator is designed to be mounted on a curb, the curb should be securely installed prior to fan installation.
4. A damper, if used, should be securely mounted within the curb or wall in a manner which allows free and unobstructed operation.
5. CAUTION! All electrical work must be done in accordance with local and/or national electrical codes as applicable. If you are unfamiliar with methods of installing electrical wiring, secure the services of a qualified electrician.
6. WARNING! This product must be grounded.
7. DANGER! Make sure power is turned off and locked in the OFF position at the service entrance before installing, wiring or servicing fan.
8. CAUTION! Before wiring the motor, check the supply voltage against the motor nameplate voltage. High or low voltage can damage the motor and void the motor warranty.
9. WARNING! Be sure to keep all wiring clear of rotating or moving parts.
10. WARNING! Before starting the fan, turn the wheel to assure it rotates freely. If needed, adjust the wheel/shaft/bearing/motor position as required to achieve necessary clearances.
11. CAUTION! On belt drive units, assure belts are tensioned and aligned properly. (See Maintenance section.)
12. WARNING! Check all set screws and keys. Tighten as necessary prior to fan startup.
13. On roof units, anchor the fan securely to the curb. Anchoring through the vertical portion of the curb cap flange is recommended. Use a minimum of four lag bolts or other suitable fasteners.
14. Due to the general nature of its applications, the basic air mover is available with protective guards and/or other devices for required operating safety as with most installations of rotating machinery. Before operating the basic unit in any of its applications determine requirements for such guards and/or devices needed for protection against accidental contact with moving parts or against injury to nearby personnel or critical equipment due to accidental rupture of fast moving parts.

## Installation, Operation, and Maintenance Manual – Start-up & Maint.

### START-UP:

Lock out the power source.

Tighten all bolts and setscrews securely and, on belt drive fans, check sheave alignment and belt tension. Tighten belts if necessary. NOTE THAT ALL BOLTS, SETSCREWS AND BELTS SHOULD BE TIGHTENED AFTER TWO DAYS OF INITIAL OPERATION.

Clearance should be checked all around between wheel or propeller tips and the housing before starting up. The wheel or propeller should not strike the housing.

No initial lubrication is required. Motors have been pre-lubricated by motor manufacturer and fan bearings by Moffitt Corporation.

Arrows to show direction of rotation and airflow are attached to the fan housings.

After the electrical connections are completed, apply just enough power to start the impeller as is indicated by the directional arrows on the unit. If the impeller is turning the wrong direction, it will not deliver rated airflow and the motor connections must be altered to correct rotation.

*Lock out the power source before the installation of all accessories.*

Fan electrical power can now be applied and special attention given to determine if motor is working properly. At this time, with air system in full operation, with guards attached, it is well for the electrician to measure the operating amperage of the motor and compare with the nameplate rating to determine that the motor is operating under safe load conditions.

The fan should not need balancing, as it was balanced at the factory to be within stringent vibration levels before shipment. However, there are several things that may cause vibration, such as rough handling in shipment and erection, weak foundations, and alignments.

### MAINTENANCE:

1. Before performing any maintenance on the fan, be sure power is turned off and locked in the OFF position at the service entrance before servicing the fan.
2. Ventilators should be carefully checked at least once a year. For critical or rugged applications, a routine check every two or three months is suggested.
3. All motors supplied with Moffitt Corporation ventilators carry a one year warranty from date of shipment. - *For repairs within the warranty period, the motor must be taken to the motor manufacturer's authorized service dealer. Contact your representative for additional warranty details.*
4. A periodic motor check should consist of spinning the motor shaft with the power off to be sure the motor turns freely and the bearings run smoothly. The belt on belt driven units should be removed from the motor sheave.
5. When removing or installing a belt, do not force the belt over the sheave. Loosen the motor mount so that the belt can be easily slipped over the sheave.
6. The belt on belt driven units should be removed and carefully checked for radial cracks, ply separation or irregular wear. A small irregularity in the contact surface of the belt will result in noisy operation. If any of these defects are apparent, the belt should be replaced. Check the sheaves also for chipping, dents or rough surfaces which could damage the belt.
7. The correct belt tension is important. Too tight a belt will result in excess bearing pressure on the motor bearings and shaft pillow block, and may also overload the motor. Too loose a belt will result in slippage which will quickly burn out belts. A belt should feel "live" when thumped, approximately 1/4" belt deflection when subject to finger pressure (3 to 5 lb.) at midpoint between sheaves.
8. The belt alignment should also be checked to be sure the belt is running perpendicular to the rotating shafts. Motor and drive shafts must be parallel. Improper alignments will result in excessive belt wear.
9. Check sheave set screws to ensure tightness. Proper keys must be in keyways.
10. Do not readjust blade pitch or fan RPM. If sheaves are replaced, use only sheaves of identical size and type.
11. If unit is to be left idle for an extended period, it is recommended that belts be removed and stored in a cool, dry place to avoid premature belt failure.
12. The standard pillow block bearings on belt driven ventilators are factory lubricated and are provided with external grease fittings. Re-lubricate annually or more frequently, if required, is recommended.
13. During the first few months of operation it is recommended that the set screws be checked to assure they are tight
14. The rotating wheel or propeller requires particular attention in most applications since materials in the air being handled can build up on the blades to cause destructive vibration; and may also corrode and/or erode the blade metal to weaken the structure of the propeller. Regular inspection and corrective action at intervals determined by the severity of each application are essential to good service life.

## Installation, Operation, and Maintenance Manual – Bearings

### BEARINGS AND LUBRICATION:

All Moffitt Corporation belt drive fan bearings are heavy duty, self-aligning ball type and are re-lubricate for continuous service.

Selection of the correct bearing grease and greasing intervals depends on several things. Extreme high or low temperatures, dirty or damp surroundings, and vibration exceeding 1 or 2 mils are all things that will require more frequent greasing or special greases. For standard service, use a lithium base grease that conforms to NLGI grade 2 consistency.

The motor bearings and the fan bearings on the belt drive fans should be greased at regular intervals. Motor manufacturer's greasing instructions and recommendation should be followed closely. Avoid the use of a pressure greasing system which tends to fill the bearing chamber completely. Do not over grease. Use only 1 or 2 shots with a hand gun in most cases. Maximum hand gun rating 40 P.S.I. Rotate bearings during lubrication where good safety practice permits. NOTE: On motors with non re-greasable sealed bearings, no lubrication is required for the life of the bearings.

Some of the most frequent causes of bearing failure is not greasing often enough, using an excessive quantity of grease, or using incompatible greases. Excessive vibration, especially if the bearing is not rotating, will also cause bearings to fail. Bearings must also be protected from water and moisture to avoid internal corrosion.

### BEARING REPLACEMENT:

Fan bearings on belt drive fans should not need to be replaced for many years if the above recommendation are strictly adhered to. However, use the following procedure when bearing replacement is necessary.

1. Gain access to the fan bearings. Remove the bearing cover, if any.
2. Loosen the belts by shifting the motor.
3. Remove the propeller and disconnect the remote lube tubes (if applicable).
4. Measure the location of the bearing to the propeller end of the shaft and the bearing spacing.
5. Remove the shaft and bearing assembly. Note the position of the bearings' shims (if applicable).
6. Loosen all bearing/shaft setscrews or other locking device.
7. Remove bearings (may have to be pressed off the shaft).
8. Polish the shaft with fine emery paper (240 Grit or finer) and file the setscrew dimples flat.
9. Install new bearings on the shaft, making sure that the collars are together, (i.e., facing each other on the shaft). Lightly seat one setscrew or eccentric locking collar on each bearing to hold in the approximate marked position.
10. Mount the shaft/bearing assembly in the fan, with bolts. Do not tighten yet. Just snug up. Loosen the setscrew.
11. Center the shaft in the housing (both ends) as closely as possible. (The fan propeller may need to be temporarily installed to get its clearances equal.)
12. Tighten the bearing mounting bolts.
13. Reinstall the lube tubes (if applicable).
14. Install bearing cover, propeller, and belts, and adjust the motor to get proper belt tension. Also, make sure that the sheaves are properly aligned.
15. If a new shaft is supplied, then ignore items #6 through #8.

## Installation, Operation, and Maintenance Manual – V-Belt

### V-Belts:

V-belts on Moffitt Corporation belt drive fans are oil, heat and static resistant type, and oversized for continuous duty. With proper installation and maintenance, years of operating efficiency can be added to the life span of the V-belt drive.

The condition of V-Belts and the amount of belt tension should be checked prior to start-up. When it becomes necessary to adjust belt tension, do not over-tighten as bearing damage will occur. Recommended belt tension should permit 1/64" per inch of span deflection of the belt on each side of the belt measure half-way between the pulley centerline. Extreme care must be exercised when adjusting V-belt as not to misalign the pulleys. Any misalignment will cause a sharp reduction in belt life and will also produce squeaky, annoying noises. On units equipped with 2 or 3 groove pulleys, adjustments must be made so that there is equal tension on all belts.

1. Where tensioning rods are not provided, adjustment is more easily obtained by loosening and adjusting one side of the motor bracket at a time.
2. Always loosen tension adjustment enough to place belts on sheaves without running belts over the edge of either sheave. A new belt may be seriously damaged internally by careless handling.

**WARNING:** Whenever belts are removed or installed, never force belts over pulleys without loosening motor first to relieve belt tension. The fan has been checked at the factory prior to shipment for mechanical noises. If mechanical noise should develop, then some suggestions are offered here as a guide remedying the cause.

1. Check rotating members for adequate clearance
2. Check proper belt tension and pulley alignment.
3. Check installation and anchoring.
4. Check fan bearings.

SEE DIAGRAMS BELOW AND ON NEXT PAGE.

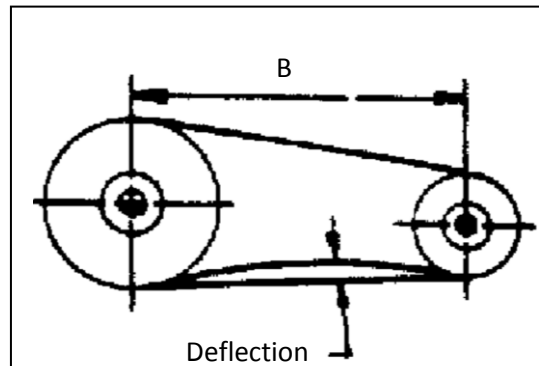

**Installation, Operation, and Maintenance Manual – V-Belt cont.**

Adjust variable pitch sheaves properly



Two-groove variable pitch sheaves must be opened the same number of turns on both sides, otherwise slippage is induced, wearing belts rapidly.

NOT THIS

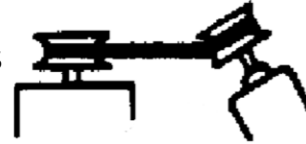

THIS



Mount belts straight. Shafts must be parallel and sheaves in alignment to prevent unnecessary belt wear.



Eliminate Slack

Slack causes belts to wear excessively, cause slippage and deliver less power. For longest belt life, always provide proper tension.



Don't Force Belt

Loosen the motor so the belt can be slipped on sheaves easily. Forcing the belt will break the cords and cause early belt failure

## Installation, Operation, and Maintenance Manual – Motor

### MOTORS

The fundamental principle of electrical maintenance is KEEP THE MOTOR CLEAN AND DRY. This requires periodic inspection of the motor. The frequency depends upon type of motor and the service.

We recommend periodic checks of voltage, frequency, and current of a motor while in operation. Such checks assure the correctness of frequency and voltage applied to the motor, and yield an indication of the fan load. Comparison of this data with previous data will give an indication of the fan performance. Any serious deviations should be investigated and corrected.

Fractional motors usually have pre-lubricated sealed bearings with no grease fittings and are lubricated for life.

Lubricate integral horsepower motors per the motor manufacturer’s recommendations. Lubrication frequency depends on the motor horsepower, speed, and service. Use compatible greases.

1. All motors carry a one year warranty from date of shipment. For repairs within the warranty period, the motor must be taken to the motor manufacturer's authorized service dealer. Contact your representative for additional warranty details.
2. A periodic motor check should consist of spinning the motor shaft with the power off to be sure the motor turns freely and ft bearings run smoothly. The belt on belt driven units should be removed from the motor pulley.

### RECOMMENDED BALL AND ROLLER BEARING GREASES SUGGESTED REGREASING INTERVALS

INTERVAL	TYPES OF SERVICE
1-2 Years	Infrequent Operation or light duty in clean, Relatively Dry Atmosphere
1 Year	8-16 Hrs/Day in Clean, Relatively Dry Atmosphere
6 Months	12-24 Hrs/Day, Heavy Duty, or if Moisture is present
3 Months	Heavy Duty in dirty, dusty locations: High Ambient Moisture, Laden Atmosphere, or Vibration

### CAUTION

Greases of different soap bases (lithium, sodium, etc.) may not be compatible when mixed. Prevent such intermixing by completely purging the bearing of old greases.

Note: Use re-greasing intervals and grease as noted in tables, unless a lubrication plate on motor indicates otherwise. Refer to motor lubrication plate for specific type and/or grade of lubricant to be used. Example:

MANUFACTURER	GREASE (NLGI No. 2)
US Electric Motors	Grease No. 83343
Chevron USA Inc.	Grease SRI Grease No. 2
Mobil Oil Corp.	Mobilux 2
Texaco, Inc.	Premium BRB No. 2

### REPAIR PARTS:

1. Belts - use only belts of the same type and size furnished.
2. Bearings - Replacement adapter bearing units are available from trade channels for installation in pillow block housings when required.
3. Fan Blades - Repair of individual fan blades or propeller assemblies is not recommended. Contact factory with blade size, number of blades, bore size, motor HP, air flow direction, rotation, fan RPM or sheave sizes and any order/tag information that is available for replacement.
4. Misc. Parts - Not available from local trade channels should be returned for repair or replacement. Be sure to obtain return tags or authorization before shipment.
5. Electric Motors - Repair or replacement of motors is normally performed by a repair station authorized by the manufacturer. Contact your representative or the factory for locations nearest to you. DO NOT ship motor to the factory without specific authorization.



## Installation, Operation, and Maintenance Manual – Motor - Warranty

### **WARRANTY:**

Moffitt Corporation warrants this equipment to be free from defects in material and workmanship for one year from date of shipment. Any units or parts which prove to be defective and are reported during the warranty period will be replaced at our option when returned to our factory, transportation prepaid. Deterioration or wear by heat, abrasive action, chemicals, improper installation or operation or lack of normal maintenance shall not constitute defects, and are not covered by warranty.

The motor is warranted by the motor manufacturer for one year. If the motor becomes defective in the warranty period, it should be taken to the nearest authorized motor service station. If this is not done, the motor manufacturer will not warrant the motor. Call the factory for instructions if authorized service station is not known.

Moffitt Corporation will not be responsible for any installation, removal or re-installation costs or any consequential damage resulting in failure to meet conditions of any warranty.

### **LIMITATION OF WARRANTY AND LIABILITY:**

This warranty does not apply to any such Moffitt Corporation product or parts which have failed as a result of faulty installation or abuse, or incorrect electrical connections or alterations, made by others, or use under abnormal operating conditions or misapplication of the products and parts.

Moffitt Corporation will not approve for payment any repairs made outside the factory without prior written consent of its Jacksonville, Florida office.

The foregoing shall constitute our sole and exclusive warranty and our sole and exclusive liability and is in lieu of all other warranties, whether written, oral, implied or statutory. There are no warranties which extend beyond the description of the page hereof. Seller does not warrant that said goods and articles are of merchantable quality or that they are fit for any particular purpose.

The liability of seller on any claim of any kind, including negligence, for any loss or damage arising out of or connected with, or resulting from the sale and purchase of the products and parts covered by this proposal, acknowledgment, order or from the performance or breach of any contract pertaining to such sale or purchase, or from the design, manufacture, sale, delivery, resale, installation, technical direction of installation, inspection, repair, operation or use of any products or parts covered by this proposal, acknowledgment, order or furnished by seller shall, in no case exceed the price allocable to the products or parts thereof which give rise to the claim and shall terminate one (1) year after the shipment of said products and parts.

In no event, whether as a result of breach of contract, or warranty or alleged negligence, defects, incorrect advice or other causes, shall seller be liable for special or consequential damages, including, but not limited to, loss of profits or revenue, loss of use of the equipment or any associated equipment, cost of capital, cost of substitute equipment, facilities or services, down time costs, or claims of customers of the purchaser for such damages. Moffitt Corporation neither assumes nor authorizes any persons to assume for it any other liability in connection with the sale of its fan products and parts. Some states do not allow the exclusion or limitation of incidental or consequential damages, so all of the above limitations or exclusions may not apply to you.

### **SAFETY ACCESSORIES WARNING:**

The responsibility for providing safety accessories for equipment supplied by Moffitt Corporation is that of the installer and user of this equipment. Moffitt Corporation sells its equipment with and without safety accessories, and accordingly it can supply such safety accessories upon receipt of order.

The user, in making its determination as to the appropriate safety accessories to be installed and any warning notices, should consider (1) the location of the installation, (2) the accessibility of employees and other persons to this equipment, (3) any adjacent equipment, (4) applicable building codes, and (5) requirements of the Federal Occupational Safety and Health Act.

Users and installers of this equipment should read "RECOMMENDED SAFETY PRACTICES FOR AIR MOVING DEVICES" which is published by Air Movement and Control Association, 30 West University Drive, Arlington Heights, Illinois 60004.

## UB3100 – UB3300 Safety Guard Basket

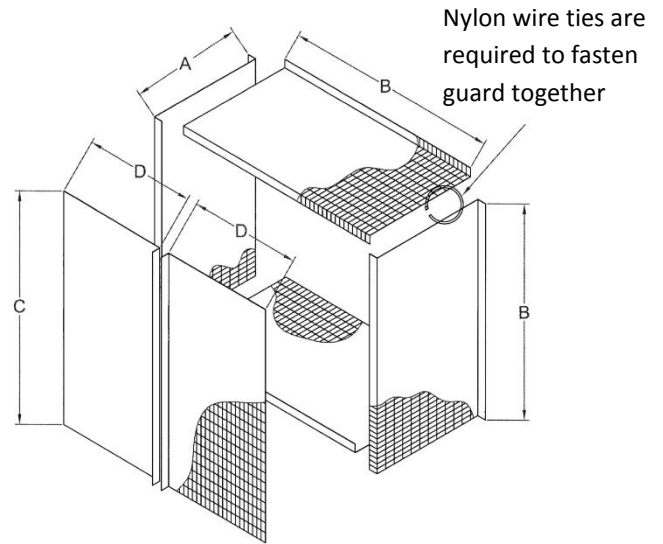
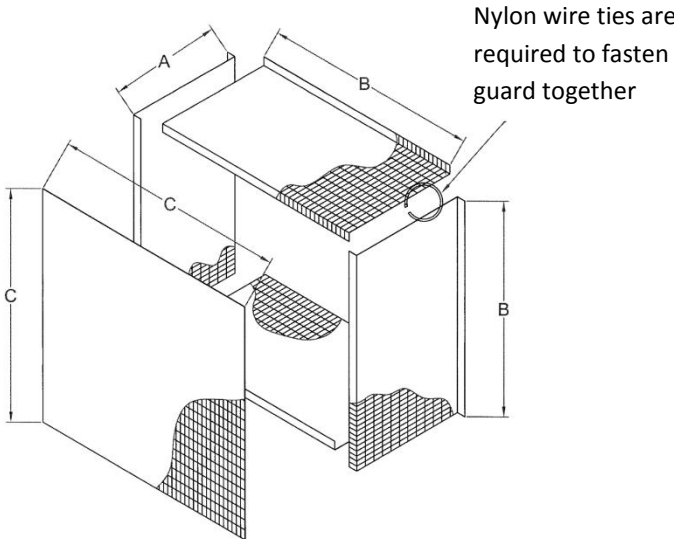

### Size 24"-54"

SIZE	LOCATION	A	B	C	QTY
24"	SIDE	16"	23"		4
24"	BACK			27"	1
30"	SIDE	16"	29"		4
30"	BACK			33"	1
36"	SIDE	16"	35"		4
36"	BACK			39"	1
42"	SIDE	16"	41"		4
42"	BACK			45"	1
48"	SIDE	16"	47"		4
48"	BACK			51"	1
54"	SIDE	16"	53"		4
54"	BACK			57"	1

### Size 60"

SIZE	LOCATION	A	B	C	D	QTY
60"	SIDE	16"	59"			
60"	BACK			59"	29.5"	4

## UB3100 - UB3300 Magnetic Damper Latch Installation Instructions

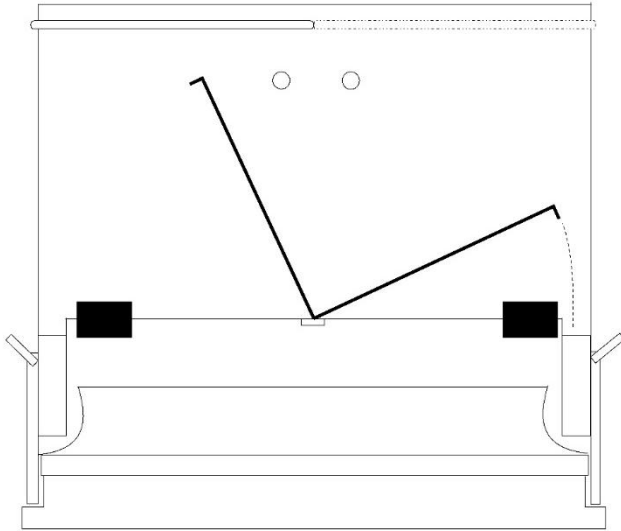

1. Locate latches as shown.
2. Attach magnet to wind band with 4 #10 self-tapping screws.
3. Attach 2" x 4" latch plate to bottom of damper doors (required on fiberglass doors) with 4 #10 self-tapping screws, making sure it makes contact with magnets on latch.
4. Make sure latch is level and true width damper for good holding power- select smooth and level damper area for installation.
5. Caulk around all screws on damper doors to eliminate leakage.

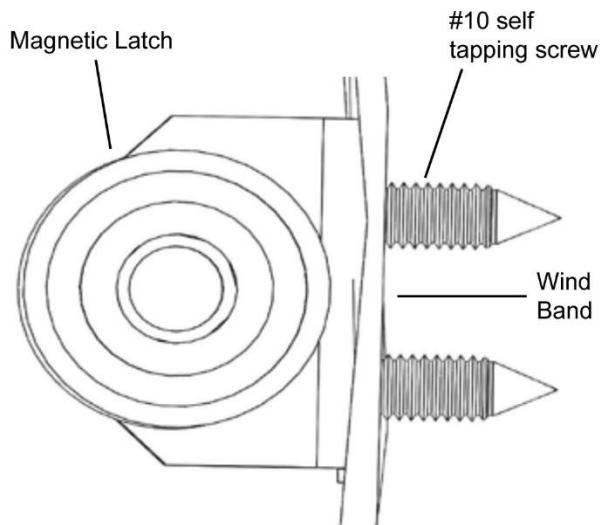

**Top View**

### Check Operation Manually

#### CHECK OPERATION MANUALLY

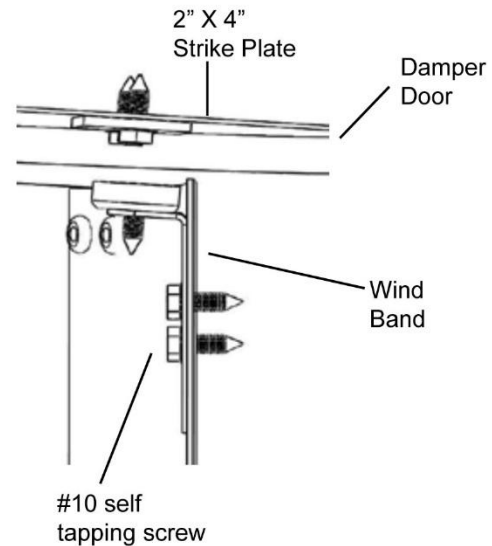

**Side View**

## UB3100 Direct Drive Upblast Roof Exhauster Guide Specification

### 1.1. DESCRIPTION

Furnish and Install UB3100 Direct Drive Propeller Up-blast Exhaust Fan and accessories as indicated on drawings.

### 1.2. QUALITY ASSURANCE

MOFFITT (Jacksonville, FL, 1 800-474-3267) Products establish the standard of quality required. Manufacturer and erector shall demonstrate a minimum of five (5) years of related industry experience.

### 1.3. SUBSTITUTIONS

No substitutions will be considered unless written request for approval has been submitted by the bidder and has been received by the designer at least ten (10) days prior to bid date. Any proposed substitutions should meet the standards set by the specification.

### 1.4. SUBMITTALS

Furnish approval drawings prior to fabrication; and erection drawings prior to shipment showing all erection procedures and accessories required for the specified product.

### 2.1. DESIGN:

2.1.1. Fan shall be a straight-through airflow design to maximize exhaust efficiency.

2.1.2. Air velocity to be adequate to open butterfly dampers. Damper to close and cover Venturi when fan is not operating.

2.1.3. Fan to be direct drive to minimize maintenance.

2.1.4. Curb Cap required for curb mounting on roof.

### 2.2. CONSTRUCTION:

2.2.1. Panel Assembly to be constructed from heavy gauge G90 galvanized steel with one piece Venturi for maximum efficiency. All welded support structure to be schedule 40 galvanized pipe with motor bearing plate to be a minimum of 10ga galvanized steel.

2.2.2. Wind band to be heavy gauge galvanized steel. Dampers to be steel construction unless otherwise specified. Bronze bushings to be provided for galvanized steel damper shaft to rotate freely. Galvanized rain channel to be provided to drain water from damper

2.2.3. Propeller to aluminum airfoil design with \_\_\_\_ (2, 3, 4, 6) blades. Hub plate to be steel Construction with taper lock type bushings. Adjustable pitch design required for optimum Efficiency. Propellers to be statically and dynamically balanced at factory before shipping.

2.2.4. Drive to be direct drive with motor sized 150% of drive horsepower. Motor to be open drip proof unless specified otherwise. Motors to be nationally recognized and locally serviced brand.

2.2.5. Bearings to be minimum 200,000 hour life design. Cast-iron self-aligning pillow blocks of the ball bearing type, sealed and pre-lubricated with re-lubricate fittings.

### 2.3. ACCESSORIES: (Select as required)

2.3.1. Fan to be Aluminum Construction.

2.3.2. Dampers to be translucent fiberglass construction.

2.3.3. Motor to be Hi-efficiency (TEFC; Explosion-proof; Corrosion Duty).

2.3.4. Safety guards to be provided at inlet and outlet of fan. ½" x 1" mesh galvanized steel screen.

2.3.5. Pre-fabricated Roof Curbs to be constructed from heavy gauge steel, welded construction.

2.3.6. Curb height to be \_\_\_\_" (8", 12", special ht) with 1 ½" treated wood nailer, flat roof. (pitched roof \_\_\_\_rise on \_\_\_\_run; double pitched roof \_\_\_\_rise on \_\_\_\_run.)

2.3.7. Roof Curbs to have burglar bars installed of \_\_\_\_" dia x \_\_\_\_centers in \_\_\_\_directions.

2.3.8. Propeller blades to be die-formed construction.

2.3.9. Non-fused Disconnect to be provided in NEMA\_\_\_\_ (1,3R,4,4X ) enclosure.

2.3.10. Magnetic Latches to be provided to limit damper chatter.

2.3.11. Heat/Smoke Vents to be provided to open damper doors when temperature exceeds 165°

2.3.12. Copper tube extended lube lines to be provided for bearing lubrication.

2.3.13. Fan to be epoxy coated finish.

2.3.14. Fan to be vinyl coated finish.

2.3.15. Fan to be coal tar coated finish.

## **UB3100 Direct Drive Upblast Roof Exhauster Guide Specification cont.**

**3.1. INSPECTION:**

Examine fan prior to installation for any damage in shipping. Report it immediately. Examine Roof Curb prior to installation to ensure a true flat mounting condition. Make sure flat surface of curb is clear of debris to ensure proper adhesion of caulking material between vent and curb surface.

**3.2. INSTALLATION AND ERECTION:**

3.2.1. Install UB3100 Direct Drive Propeller Up-blast Exhaust Fan and Accessories in conformance with approved drawings and MOFFITT specifications.

3.2.2. Any necessary hardware and caulking for ventilator shall be included with units.

3.2.3. Any additional material to be provided by installing contractor.

**3.3. DAMAGED MATERIAL:**

Repair or replace all damaged material.

## UB3300 Belt Drive Upblast Roof Exhauster Guide Specification

### 1.1. DESCRIPTION

Furnish and Install UB3300 Belt Drive Propeller Up-blast Exhaust Fan and accessories as indicated on drawings.

### 1.2. QUALITY ASSURANCE

MOFFITT (Jacksonville, FL, 1 800-474-3267) Products establish the standard of quality required. Manufacturer and erector shall demonstrate a minimum of five (5) years of related industry experience.

### 1.3. SUBSTITUTIONS

No substitutions will be considered unless written request for approval has been submitted by the bidder and has been received by the designer at least ten (10) days prior to bid date. Any proposed substitutions should meet the standards set by the specification.

### 1.4. SUBMITTALS

Furnish approval drawings prior to fabrication; and erection drawings prior to shipment showing all erection procedures and accessories required for the specified product.

### 2.1. DESIGN

2.1.1. Fan shall be a straight-through airflow design to maximize exhaust efficiency.

2.1.2. Air velocity to be adequate to open butterfly dampers. Damper to close and cover venturi when fan is not operating.

2.1.3. Fan to be belt drive to afford quieter operation and wider range of performance.

2.1.4. Curb Cap required for curb mounting on roof.

### 2.2. CONSTRUCTION

2.2.1. Panel Assembly to be constructed from heavy gauge G90 galvanized steel with one piece venturi for maximum efficiency. All welded support structure to be schedule 40 galvanized pipe with motor bearing plate to be a minimum of 10ga galvanized steel.

2.2.2. Wind band to be heavy gauge galvanized steel. Dampers to be steel construction unless otherwise specified. Bronze bushings to be provided for galvanized steel damper shaft to rotate freely. Galvanized rain channel to be provided to drain water from damper

2.2.3. Propeller to aluminum airfoil design with \_\_\_\_ (2, 3, 4, 6) blades. Hub plate to be steel construction with taper lock type bushings. Adjustable pitch design required for optimum efficiency. Propellers to be statically and dynamically balanced at factory before shipping.

2.2.4. Drive to be belt drive with motor sized 150% of drive horsepower. Single belt adjustable pitch sheave to be used to 3hp. (Two belt fixed sheaves through 10 hp; 3 belt fixed pitch sheaves on 15hp motor). Drives have adjustable tension rods for belt adjustment, and non-static oil resistant V-belts. Shafts to be keyed, turned, ground and polished. Motor to be open drip proof unless specified otherwise. Motors to be nationally recognized and locally serviced brand.

2.2.5. Bearings to be minimum 200,000 hour life design. Cast-iron self-aligning pillow blocks of the ball bearing type, sealed, pre-lubricated and have serviceable grease fittings.

### 2.3. ACCESSORIES (Select as required)

2.3.1. Fan to be Aluminum Construction.

2.3.2. Motor to be High Efficiency (TEFC; Explosion-proof; Corrosion duty).

2.3.3. Dampers to be translucent fiberglass construction.

2.3.4. Drive sheaves to be adjustable pitch design to allow performance adjustment.

2.3.5. Safety guards to be provided at inlet and outlet of fan. ½" x 1" mesh galvanized steel screen.

2.3.6. Pre-fabricated Roof Curbs to be constructed from heavy gauge steel, welded construction.

2.3.7. Curb height to be \_\_\_\_" (8", 12", special ht) with 1 ½" treated wood nailer, flat roof. (pitched roof \_\_\_\_rise on \_\_\_\_run; double pitched roof \_\_\_\_rise on \_\_\_\_run.)

2.3.8. Roof Curbs to have burglar bars installed of \_\_\_\_" dia x \_\_\_\_centers in \_\_\_\_directions.

2.3.9. Propeller blades to be die-formed construction.

2.3.10. Non-fused Disconnect to be provided in NEMA \_\_\_\_ (1, 3R, 4, 4X) enclosure.

2.3.11. Magnetic Latches to be provided to limit damper chatter.

2.3.12. Heat/Smoke Vents to be provided to open damper doors when temperature exceeds 165 degrees.

2.3.13. Copper tube extended lube lines to be provided for bearing lubrication.

## **UB3300 Belt Drive Upblast Roof Exhauster Specification cont.**

2.3.14. Fan to be epoxy coated finish.

2.3.15. Fan to be vinyl coated finish.

### **3.1. INSPECTION**

3.1.1. Examine fan prior to installation for any damage in shipping. Report it immediately.

3.1.2. Examine Roof Curb prior to installation to ensure a true flat mounting condition. Make sure flat surface of curb is clear of debris to ensure proper adhesion of caulking material between vent and curb surface.

### **3.2. INSTALLATION AND ERECTION**

3.2.1. Install UB3300 Belt Drive Propeller Up-blast Exhaust Fan and Accessories in conformance with approved drawings and MOFFITT specifications.

3.2.2. Any necessary hardware and caulking for ventilator shall be included with units.

3.2.3. Any additional material to be provided by installing contractor.

### **3.3. DAMAGED MATERIAL**

Repair or replace all damaged material.