

Upblast Fan

Powered Ventilation Roof Exhaust Fan | UB3700 / UB3700-HT



MoffittCorp.com | (800) 474-3267
1351 13th Ave S. Suite 130 Jacksonville Beach, FL 32250



UB3700 - 3700HT Table of Contents

UB3700 Upblast Roof Exhausters Product Details.....	2
UB3700 / UB3700-HT Series Tube Upblast Fan Submittal Data	3
UB3700 Axial Upblast Fan Performance Data - Aluminum Blade.....	4
UB3700 Axial Upblast Fan Performance Data - Aluminum Blade cont.....	5
UB3700 Axial Upblast Fan Performance Data - Polypropylene Blade	6
UB3700 Axial Upblast Fan Performance Data - Polypropylene Blade cont.	7
UB3700-HT Series Capacity Table - Steel Blade	8
UB3700-HT Series Capacity Table - Steel Blade cont.....	9
UB3700 / UB3700-HT Safety Guard Basket	10
UB3700 / UB3700-HT Magnetic Damper Latch Installation Instructions	11
UB3700 Tube Axial Upblast Fan Guide Specification.....	12
UB3700 Tube Axial Upblast Fan Guide Specification cont.....	13
UB3700-HT High Temperature Upblast Fan Guide Specification	14
UB3700-HT High Temperature Upblast Fan Guide Specification cont.	15

UB3700 / UB3700-HT Upblast Roof Exhausters Product Details

STANDARD FEATURES

- Sizes: 24" – 120"
- CFM Range: 5,000 – 100,000 +
- Belt Driven
- Statically & Dynamically Balanced Aluminum Propeller
- All Galvanized Steel Construction
- Variable Pitch Drives Standard Through 3 HP
- Drives Sized for a Minimum 150% of Drive Horsepower
- 1 Year Fan and Motor Warranty
- Removable Panel for Easy Damper Access
- Heavy Duty 200,000 Hour Rated Pillow Block Bearings
- Low Profile
- Integral Deep Spun Inlet
- Motor: Open Drip Proof
- Bird screen: ½" mesh, 19 ga. galvanized steel
- Complete Operation & Maintenance instructions along with assembly drawings
- Units have been tested and rated in accordance with AMCA standards. Guaranteed to perform as stated.

BENEFITS

- Sturdy Construction
- Heavy Duty Motor
- Guaranteed to perform as stated

APPLICATIONS

- Steel Plants
- Aluminum Plants
- Glass Plants
- Power Plants
- General Manufacturing Plants
- Chemical Plants
- Mine Processing Plants
- Warehouses
- Pulp and Paper Plants
- Gypsum Wallboard Plants
- Plastics Plants

PRODUCT DESCRIPTION

Moffitt Corporation's Upblast fans are designed for standard duty roof mount applications for exhausting building air to provide general ventilation of hot, stagnant areas. The series 3000 vertically exhausts the building air away from the roof and is available in direct and belt drive configurations. Sizes available range from 12" thru 120".

OPTIONAL FEATURES

- Construction
 - Aluminum
 - Stainless Steel
- Propeller, FRP blades with cast aluminum hub
- Fiberglass damper doors
- Cushion Close (Steel Doors Only)
- Magnetic latches
- Outlet Guard
- Safety basket guard
- Extended Lube Lines (Belt Drive)
- Roof Curbs
- Curb Cap Adaptor Max 4" + or -
- Access Door (Bolted)
- Disconnect Switch
- High Temperature model (HT) tested to 1000°F for 15 minutes; 500°F 4 hours-IR/SBCCI
- Coatings
 - Epoxy
 - Heresite
 - Coal Tar

- Units tested and rated in accordance with AMCA Standards

UB3700 / UB3700-HT Series Tube Upblast Fan Submittal Data

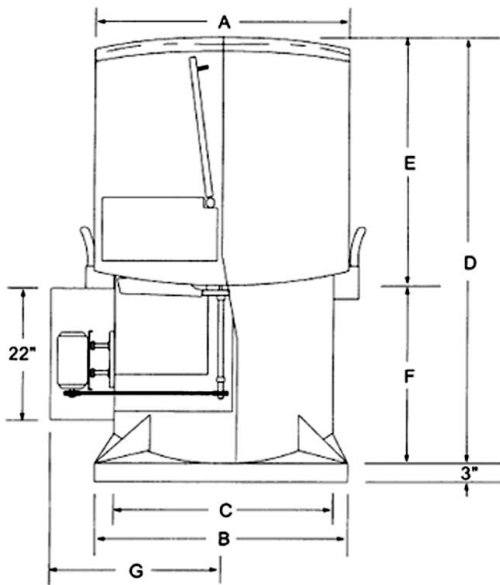

UB3700 Standard Features

- Heavy gauge welded galvanized construction
- Statically and dynamically balanced propeller
- Variable pitch drive (through 3 HP)
- Drives sized for 150% of motor HP
- 1 year fan and motor warranty
- 200,000 hour pillow block ball bearings
- Butterfly damper doors
- Aluminum or polypropylene propeller
- Factor run test
- Integral lifting lugs

UB3700-HT Standard Features

- UL-793 listed Power Ventilator for smoke control systems
- Meet the requirements of UL-793 snow load test
- All ferrous construction in airstream
- 165°F fusible link in damper release mechanism (heat and smoke vent)
- Motor out-of-airstream
- Belt and bearing enclosed in ventilated house
- Shaft heat slinger
- Dual groove drive
- Extended lube line
- Integral lifting lugs
- Heat tested to 1000°F
- 15 minutes; 500°F 4 hours- IR/SBCCI

Size	A	B	C	D	E	F	G (max)	Fan Housing	Wind Shroud	Curb Cap
24	30	35	25 1/8	55 1/2	25	30 1/2	37	12	18	14
30	36	41	31 1/8	58 1/2	28	30 1/2	40	12	18	14
36	42	47	37 1/8	60 1/2	30	30 1/2	43	12	18	14
42	48	53	43 1/8	65 1/2	33	32 1/2	46	12	18	14
48	54	59	49 1/8	68 1/2	36	32 1/2	49	10	18	14
54	60	65	55 1/8	71 1/2	39	32 1/2	52	10	18	14
60	66	71	61 1/8	74 1/2	42	32 1/2	55	10	18	10
72	80	85	13 1/8	80 1/2	48	32 1/2	62	10	18	10

Fan Specifications								
Line	QTY	Model No.	Tag	CFM	Static	Fan RPM	BHP	Sones
1								
2								
3								
4								
5								

Motor Specifications				
HP	Volts	Phase	Hertz	Encl.

UB3700 Axial Upblast Fan Performance Data - Aluminum Blade

Model UB3700	CFM @ Static Pressure								HP	RPM	No. of Blades	Max. BHP	Sones @ 5 Ft.
	0	1/8	1/4	3/8	1/2	5/8	3/4	1					
24	6210	5807	5171	4321					3/4	1200	3	0.83	19
	6805	6443	5948	5201	4415				1	1315	3	1.09	24
	7840	7537	7162	6651	5979	5306	4519		1 1/2	1515	3	1.65	29
	8668	8398	8081	7688	7156	6544	5936	4531	2	1675	3	2.22	38
30	9035	8175	6911						3/4	915	3	0.83	23
	9973	9213	8219	6789					1	1010	3	1.11	24
	11405	10755	9989	8955	7664	6304			1 1/2	1155	3	1.65	32
	12590	12009	11351	10554	9495	8312	7079		2	1275	3	2.21	38
	14318	13813	13262	12642	11903	10974	9935	7778	3	1450	3	3.22	45
	12579	10986	8694						3/4	740	3	0.82	19
36	13854	12440	10596						1	815	3	1.10	20
	15894	14689	13275	11404	9161				1 1/2	935	3	1.66	26
	17424	16337	15110	13611	11713	9660			2	1025	3	2.19	30
	19719	18769	17734	16568	15162	13476	11652		3	1160	3	3.14	36
	23798	23021	22201	21324	20373	19306	18074	15197	5	1400	3	5.47	68
	27028	26347	25639	24897	24114	23277	22371	20220	7 1/2	1590	3	7.97	89
	14588								3/4	550	4	0.84	22
	16046	14024	11621						1	605	4	1.04	23
42	18300	16539	14632	12265					1 1/2	690	4	1.57	24
	20157	18561	16898	14949	12723				2	760	4	2.11	29
	23074	21682	20029	18749	16978	15038	12727		3	870	4	3.28	36
	29694	26140	24961	23751	22474	21049	19441	15994	5	1030	4	5.17	45
	32037	30976	29849	28647	27358	25974	24473	21207	7 1/2	1310	3	7.87	57



The sound ratings shown are loudness values in fan sones at 5 ft. (1.5m) in a hemispherical free field calculated per AMCA Standard 301 @ free air. Brake horsepower does not include drive losses. Values are installation Type A, free inlet fan sone levels. Performance shown are for types and units without inlet or outlet ducts.

UB3700 Axial Upblast Fan Performance Data - Aluminum Blade cont.

Model UB3700	CFM @ Static Pressure								HP	RPM	No. of Blades	Max. BHP	Sones @ 5 Ft.
	0	1/8	1/4	3/8	1/2	5/8	3/4	1					
48	20266	16694							1	500	4	1.12	24
	23104	20044	16726						1 1/2	570	4	1.67	25
	25536	22821	19815	16733					2	630	4	2.25	26
	29184	26863	24237	21647	18899	14356			3	720	4	3.33	35
	34656	32749	30623	28375	26210	23907	21375		5	855	4	5.51	43
	39519	37871	36068	34141	32163	30271	28304	23692	7 1/2	975	4	7.88	51
	45327	43576	41742	39672	37424	35052	32652	28246	10	1175	3	10.87	73
54	31028	26996	23045	19851					3	600	4	3.09	33
	38951	35127	30055	26760	24164	18353			5	710	4	5.32	44
	44741	41411	37455	32829	29414	26206	20758		7 1/2	850	3	7.91	54
	49215	46040	42878	38781	34681	31975	29019	18913	10	935	3	10.89	62
60	33008	22992							3	485	3	3.15	38
	39133	31577	24734						5	575	3	5.18	39
	44918	38963	30343	27344	19516				7 1/2	660	3	8.15	51
	49342	44124	36563	31592	28304				10	725	3	10.93	59



The sound ratings shown are loudness values in fan sones at 5 ft. (1.5m) in a hemispherical free field calculated per AMCA Standard 301 @ free air. Brake horsepower does not include drive losses. Values are installation Type A, free inlet fan sone levels. Performance shown are for types and units without inlet or outlet ducts.

UB3700 Axial Upblast Fan Performance Data - Polypropylene Blade

Model UB3700	CFM @ Static Pressure								HP	RPM	No. of Blades	Max. BHP	Sones @ 5 Ft.
	0	1/8	1/4	3/8	1/2	5/8	3/4	1					
24	6350	5962	5491	4980					3/4	1275	6	0.75	17
	6998	6680	6180	5755	5268	4595			1	1390	6	1.00	20
	8265	7943	7615	7267	6873	6421	5382		1 1/2	1615	6	1.50	26
	9246	8996	8697	8408	8190	7731	6942	5924	2	1500	6	2.00	36
	10626	10323	10121	9875	9619	9342	8731	8042	3	2050	6	3.00	39
30	8697	7942	6919						3/4	975	6	0.75	19
	9775	9121	8323	7321					1	1080	6	1.00	20
	11515	10920	10321	9646	8797	7870			1 1/2	1250	6	1.50	24
	12821	12222	11727	11224	10523	9719	7823		2	1375	6	2.00	26
	14525	14029	13623	13124	12628	12031	10741	8914	3	1550	6	3.00	34
	17514	17112	16694	16301	15913	15491	41631	13585	5	1850	6	5.00	52
36	14809	13921	12488	11222	8630				1 1/2	930	6	1.50	24
	16823	16002	14911	13692	12481	10275			2	1040	6	2.00	28
	19331	18540	17681	16791	15710	14722	11081		3	1180	6	3.00	34
	22940	22026	21560	20890	20018	19230	17450	15008	5	1385	6	5.00	39
	26230	25850	25120	24562	23900	23243	21900	20144	7 1/2	1585	6	7.50	50
	29020	28671	28028	27670	27016	26560	25048	24010	10	1750	6	10.00	71
42	17451	15670	13561	10019					1 1/2	750	6	1.5	20
	19563	17981	16195	14986	10126	8126	-	-	2	825	6	2	32
	22893	21562	20128	18673	16892	14457	-	-	3	950	6	3	33
	27670	26551	25253	24030	22968	21616	18018	12775	5	1130	6	5	39
	31120	30830	30039	29130	28312	27022	24790	21100	7 1/2	1300	6	7.5	50



The sound ratings shown are loudness values in fan sones at 5 ft. (1.5m) in a hemispherical free field calculated per AMCA Standard 301 @ free air. Brake horsepower does not include drive losses. Values are installation Type A, free inlet fan sone levels. Performance shown are for types and units without inlet or outlet ducts.

UB3700 Axial Upblast Fan Performance Data - Polypropylene Blade cont.

Model UB3700	CFM @ Static Pressure								HP	RPM	No. of Blades	Max. BHP	Sones @ 5 Ft.
	0	1/8	1/4	3/8	1/2	5/8	3/7	1					
48	20303	18249	15126						1 1/2	620	8	1.50	24
	21414	19321	16364						2	650	8	2.00	26
	25236	23381	21684	19291	16061				3	750	8	3.00	28
	30791	29108	27464	25852	24142	22122	15276		5	890	8	5.00	36
	35748	34126	32561	31213	29792	28382	24298	18203	7 1/2	1015	8	7.50	50
	39574	38235	36780	35453	34243	33033	30691	26405	10	1120	8	10.00	55
	45670	44394	43334	42224	41014	39694	37637	35432	15	1285	8	15.00	72
54	31896	28991	24252						3	600	6	3.00	26
	34454	33006	31283	28892	25962	22632			5	730	8	5.00	33
	40051	38596	37383	35663	33543	31323	25762		7 1/2	835	8	7.50	39
	44750	43544	42334	41124	39504	37683	33343	28192	10	925	8	10.00	43
	51252	50115	49105	48094	46974	45764	42334	38593	15	1040	8	15.00	56
60	44454	40914	37683	33704	28292				5	640	6	5.00	36
	52235	49105	46274	43344	40015	35963			7 1/2	735	6	7.50	39
	58295	55465	52735	50015	47484	44354			10	810	6	10.00	50
	60116	58695	57185	55565	54055	52535	49205	45164	15	926	8	15.00	56
	75267	73060	72187	68796	66576	64456	60316	55465	20	1025	6	20.00	71



The sound ratings shown are loudness values in fan sones at 5 ft. (1.5m) in a hemispherical free field calculated per AMCA Standard 301 @ free air. Brake horsepower does not include drive losses. Values are installation Type A, free inlet fan sone levels. Performance shown are for types and units without inlet or outlet ducts.

UB3700-HT Series Capacity Table - Steel Blade

Model UB3100	CFM @ Static Pressure							HP	RPM	Max. BHP	Sones @ 5 Ft.
	0	1/8	1/4	3/8	1/2	5/8	3/4				
24	6255	5297	4821	4035				3/4	1215	0.78	21
	6975	6494	5328					1	1335	1.08	27
	7896	7272	6601	6216	5814	5248		1 1/2	1530	1.53	31
	8693	8109	7688	7265	6276	5409		2	1750	2.05	40
30	9631	8703	6835	6478				1	1180	1.06	26
	11324	10716	9408	7755	6574			1 1/2	1155	1.57	29
	11952	11272	10694	9776	8405	7824		2	1550	2.09	35
	13871	13059	12491	11234	10295	8173		3	1325	3.08	34
	16225	15983	15120	14730	12761	10576	8568	5	1560	5.13	42
	36	14173	13128	11822	10471				1 1/2	1015	1.61
15114		14353	13243	11988	10514	8772	7444	2	1160	2.11	32
18020		16740	16186	14342	10549	9510	7865	3	1140	3.05	38
20849		20157	19368	18978	16490	14118	11362	5	1245	5.12	53
18628		17503	15264	12855	11606			2	930	2.01	29
22193		20384	18866	17337	15643	13574		3	1140	3.13	38
25960		24822	23667	22374	20839	19521	18043	5	1140	5.07	48
29490		28518	28186	26569	24926	23934	19623	7 1/2	1140	7.81	58
42	16046	14024	11621					1	605	1.04	23
	18300	16539	14632	12265				1 1/2	690	1.57	24
	20157	18561	16898	14949	12723			2	760	2.11	29
	23074	21682	20029	18749	16978	15038	12727	3	870	3.28	36
	29694	26140	24961	23751	22474	21049	19441	5	1030	5.17	45
	32037	30976	29849	28647	27358	25974	24473	7 1/2	1310	7.87	57



The sound ratings shown are loudness values in fan sones at 5 ft. (1.5m) in a hemispherical free field calculated per AMCA Standard 301 @ free air. Brake horsepower does not include drive losses. Values are installation Type A, free inlet fan sone levels. Performance shown are for types and units without inlet or outlet ducts.

UB3700-HT Series Capacity Table - Steel Blade cont.

Model UB3700HT	CFM @ Static Pressure							HP	RPM	Max. BHP	Sones @ 5 Ft.
	0	1/8	1/4	3/8	1/2	5/8	3/4				
48	23071	20547	17036	14446	9318			2	1060	2.13	31
	27001	25050	22614	18159	12350			3	745	3.08	32
	32214	30087	28244	24584	21171	17307		5	920	5.12	41
	37275	35069	34092	31881	29474	24436	20370	7 1/2	1220	7.61	56
	41738	39120	38422	36114	34990	27506	25067	10	1030	10.81	66
	39519	37871	36068	34141	32163	30271	28304	7 1/2	975	7.88	51
	45327	43576	41742	39672	37424	35052	32652	10	1175	10.87	73
54	28569	25768	22833	18300				3	760	3.04	28
	36440	34307	32085	28209	21065			5	780	5.16	37
	42632	40823	38562	36009	29864	23065		7 1/2	900	7.55	48
	47064	45427	43602	41604	38006	30622		10	860	10.08	52
60	49325	48358	47390	45974	42307	37941	34800	15	780	15.71	62
	35718	32721	24429	19438				3	530	3.11	28
	42487	40061	35933	30065	25302	22050		5	640	5.18	35
	48378	45938	43009	38690	35690	30406		7 1/2	800	7.59	47
	54617	50622	48428	45938	37363	29993		10	845	10.13	53
	57143	54850	52557	50264	47971	42759	35297	15	675	15.61	62



The sound ratings shown are loudness values in fan sones at 5 ft. (1.5m) in a hemispherical free field calculated per AMCA Standard 301 @ free air. Brake horsepower does not include drive losses. Values are installation Type A, free inlet fan sone levels. Performance shown are for types and units without inlet or outlet ducts.

UB3700 / UB3700-HT Safety Guard Basket

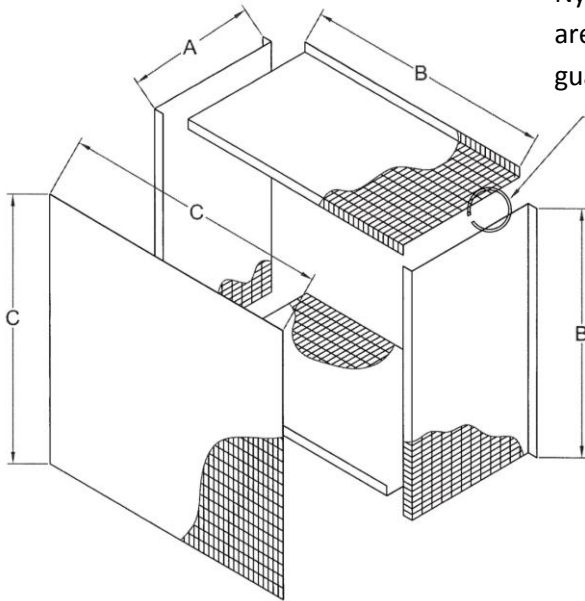

Nylon wire ties
are required to fasten
guard together

Size 24"-54"

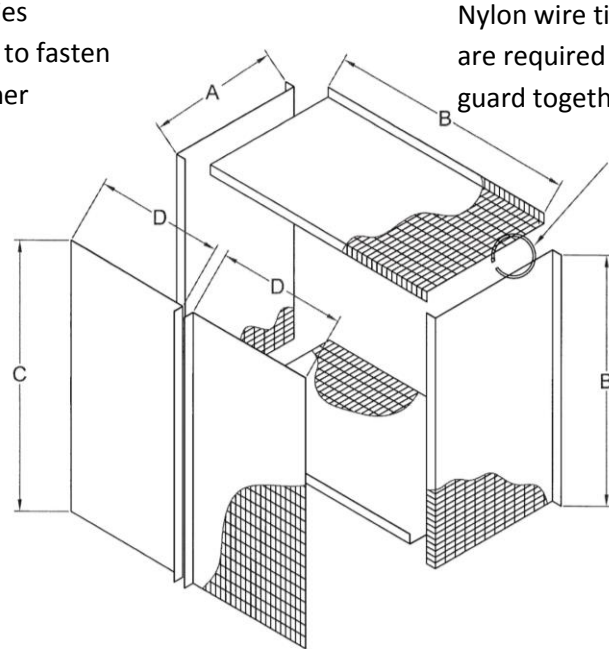

Nylon wire ties
are required to fasten
guard together

Size 60"

Size	Location	A	B	C	QTY
24"	Side	16"	23"		4
24"	Back			27"	1
30"	Side	16"	29"		4
30"	Back			33"	1
36"	Side	16"	35"		4
36"	Back			39"	1
42"	Side	16"	41"		4
42"	Back			45"	1
48"	Side	16"	47"		4
48"	Back			51"	1
54"	Side	16"	53"		4
54"	Back			57"	1

Size	Location	A	B	C	D	QTY
60"	Side	16"	59"			4
60"	Back			59"	29.5"	2

UB3700 / UB3700-HT Magnetic Damper Latch Installation Instructions

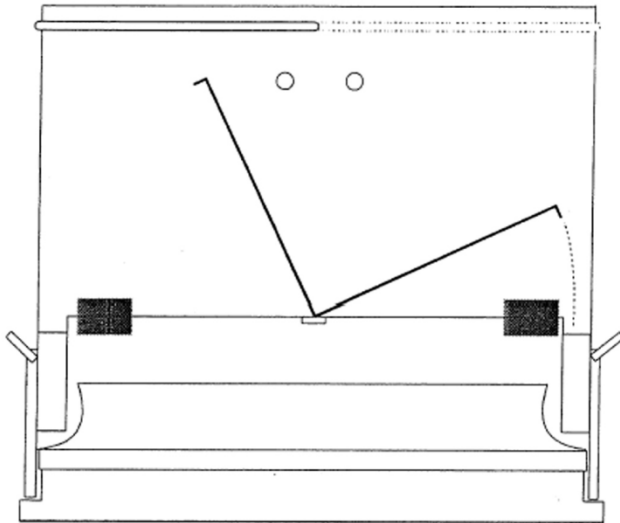

1. Locate latches as shown.
2. Attach magnet to wind band with 4 #10 self-tapping screws.
3. Attach 2" x 4" latch plate to bottom of damper doors (required on fiberglass doors) with 4 #10 self-tapping screws, making sure it makes contact with magnets on latch.
4. Make sure latch is level and true with damper for good holding power- select smooth and level damper area for installation.
5. Caulk around all screws on damper doors to eliminate leakage.

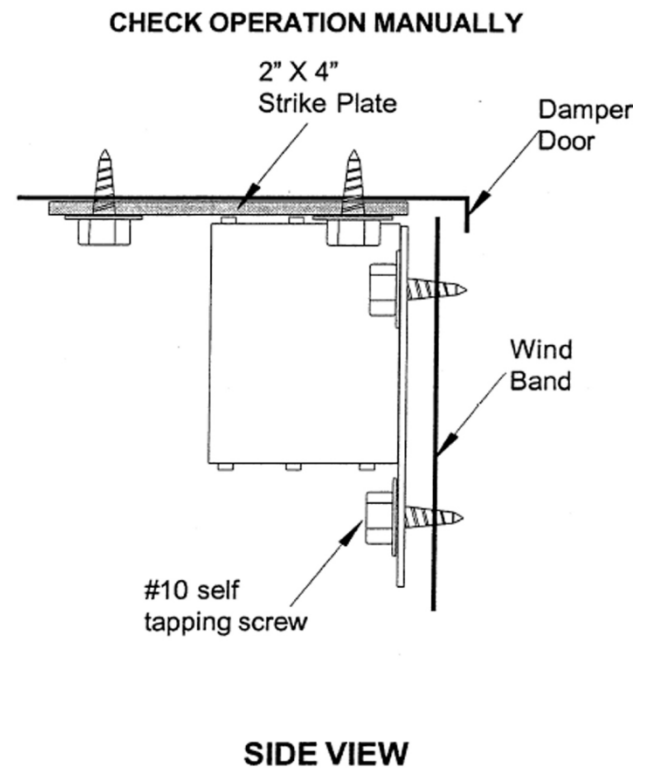
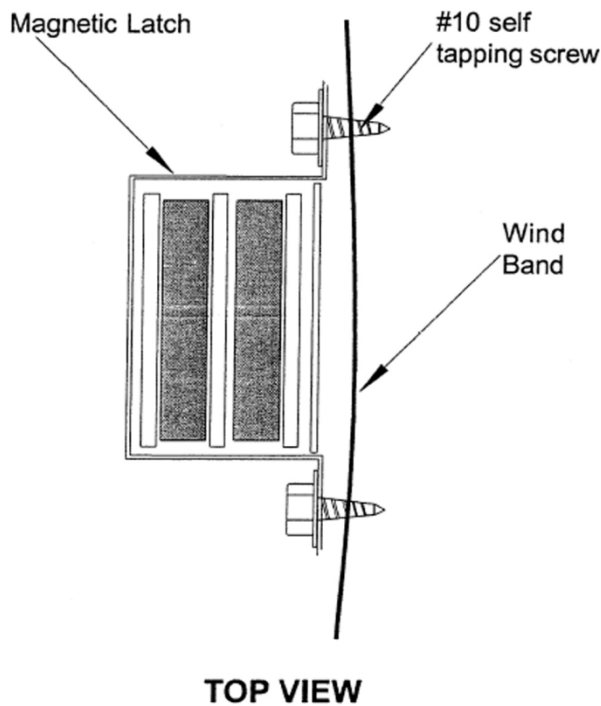

UB3700 Tube Axial Upblast Fan Guide Specification

1.1. DESCRIPTION

Furnish and Install UB3700 Belt Drive Tube Axial Propeller Up-blast Exhaust Fan and accessories as indicated on drawings.

1.2. QUALITY ASSURANCE

MOFFITT (Jacksonville, FL, 1 800-474-3267) Products establish the standard of quality required. Manufacturer and erector shall demonstrate a minimum of five (5) years of related industry experience.

1.3. SUBSTITUTIONS

No substitutions will be considered unless written request for approval has been submitted by the bidder and has been received by the designer at least ten (10) days prior to bid date. Any proposed substitutions should meet the standards set by the specification.

1.4. SUBMITTALS

Furnish approval drawings prior to fabrication; and erection drawings prior to shipment showing all erection procedures and accessories required for the specified product.

2.1. DESIGN

- 2.1.1. Fan shall be a straight-through airflow design to maximize exhaust efficiency.
- 2.1.2. Air velocity to be adequate to open butterfly dampers. Damper to close and cover venturi when fan is not operating.
- 2.1.3. Fan to be remote belt drive configuration with motor, bearings, and belts shielded from airstream by a metal enclosure. Fan to be capable of continuous operation in air temperatures up to 200° F.
- 2.1.4. Units to be tested in accordance with AMCA301 (sound) and AMCA 210 (air) in a certified lab.
- 2.1.5. Units to be completely assembled and factory tested for quality assurance prior to shipment.
- 2.1.6. Curb Cap required for curb mounting on roof.

2.2. CONSTRUCTION

- 2.2.1. Fan Tube shall be heavy gauge, G-90 galvanized steel for 24" through 54" (10hp); 60" shall be Carbon Steel primed and finished in grey epoxy paint. Tubes to be welded one- piece construction with 2" flanged ends for maximum strength. Up-blast Wind band to be heavy gauge galvanized steel with dampers of steel construction unless otherwise specified. Bronze bushings to be provided for galvanized steel damper shaft to rotate freely. Galvanized rain channel to be provided to drain water from damper.
- 2.2.2. Bearing Plate shall be a minimum 10ga, G-90 galvanize steel, welded in place and protected from the airstream by welded heavy ga steel sheet metal enclosure.
- 2.2.3. Propeller to high strength aluminum airfoil design with ____ (3, 4, 6, 8) blades. Hub plate to be steel construction. Adjustable pitch design required for optimum efficiency. Propellers to be statically and dynamically balanced at factory before shipping.
- 2.2.4. Motors, bearings and belts to be shielded from the airstream by a bolted sheet metal enclosure. Drive to be belt drive with motor sized 150% of drive horsepower. Single belt adjustable pitch sheave to be used to 3hp. (Two belt fixed sheaves through 10 hp; 3 belt fixed pitch sheaves on 15hp motor; 4 belt fixed pitch on 20hp). Drives to be adjusted with sliding motor base and use non-static oil resistant V-belts. Shafts to be keyed, turned, ground and polished. Motor to be open drip proof unless specified otherwise. Motors to be nationally recognized and locally serviced brand.
- 2.2.5. Bearings to be minimum 200,000 hour life design. Cast-iron self-aligning pillow blocks of the ball bearing type, double-sealed, pre-lubricated and have extended lube Lines to serviceable grease fittings.
- 2.2.6. Integral Lifting Lugs required.

2.3. ACCESSORIES (Select as required)

- 2.3.1. Fan to be Aluminum Construction. 24" to 48" with Welded Aluminum angle flanges.
- 2.3.2. Motor to be High Efficiency (TEFC; Explosion-proof; Corrosion duty)
- 2.3.3. Drive sheaves to be adjustable pitch design to allow performance adjustment.
- 2.3.4. Safety guards to be provided at inlet and outlet of fan. ½" x 1" mesh galvanized steel screen.

UB3700 Tube Axial Upblast Fan Guide Specification cont.

- 2.3.5. Pre-fabricated Roof Curbs to be constructed from heavy gauge steel, welded construction. Curb height to be ____" (8", 12", special ht) with 1 ½" treated wood nailer, flat roof. (Pitched roof ___rise on ___run; double pitched roof ___rise on ___run.)
 - 2.3.6. Roof Curbs to have burglar bars installed of ____" dia x ____centers in ____directions.
 - 2.3.7. Propeller blades to be corrosive resistant Polypropylene with Die Cast Aluminum Hub.
 - 2.3.8. Non-fused Disconnect to be provided in NEMA__ (1, 3R, 4,4X) enclosure.
 - 2.3.9. Magnetic Latches to be provided to limit damper chatter.
 - 2.3.10. Heat/Smoke Vents to be provided to open damper doors when temperature exceeds 165°.
 - 2.3.11. Fan to be epoxy coated finish.
 - 2.3.12. Fan to be vinyl coated finish.
 - 2.3.13. Fan to be coal tar coated finish.
- 3.1. **INSPECTION**
Examine fan prior to installation for any damage in shipping. Report it immediately. Examine Roof Curb prior to installation to ensure a true flat mounting condition. Make sure flat surface of curb is clear of debris to ensure proper adhesion of caulking material between vent and curb surface.
- 3.2. **INSTALLATION AND ERECTION**
- 3.2.1. Install UB3700 Belt Drive Tube Axial Propeller Up-blast Exhaust Fan and accessories in conformance with approved drawings and Moffitt specifications.
 - 3.2.2. Any necessary hardware and caulking for ventilator shall be included with units.
 - 3.2.3. Any additional material to be provided by installing contractor.
- 3.3. **DAMAGED MATERIAL**
Repair or replace all damaged material.

**Note: Specifications are for up to 60" Units. Please consult factory for requirements larger sizes.*

UB3700-HT High Temperature Upblast Fan Guide Specification

1.1. DESCRIPTION

Furnish and Install UB3700-HT High Temperature Belt Drive Tube Axial Propeller Up-blast Exhaust Fan and accessories as indicated on drawings.

1.2. QUALITY ASSURANCE

MOFFITT (Jacksonville, FL, 1 800-474-3267) Products establish the standard of quality required. Manufacturer and erector shall demonstrate a minimum of five (5) years of related industry experience.

1.3. SUBSTITUTIONS

No substitutions will be considered unless written request for approval has been submitted by the bidder and has been received by the designer at least ten (10) days prior to bid date. Any proposed substitutions should meet the standards set by the specification.

1.4. SUBMITTALS

Furnish approval drawings prior to fabrication; and erection drawings prior to shipment showing all erection procedures and accessories required for the specified product.

2.1. DESIGN:

- 2.1.1. Fan shall be a straight-through airflow design to maximize exhaust efficiency.
- 2.1.2. Air velocity to be adequate to open butterfly dampers. Damper to close and cover venturi when fan is not operating.
- 2.1.3. Fan to be remote belt drive configuration with motor, bearings, and belts shielded from airstream by a metal enclosure. Fan to be capable of continuous operation in air temperatures up to 200° F.
- 2.1.4. Units to be tested in accordance with AMCA301 (sound) and AMCA 210 (air) in a certified lab.
- 2.1.5. Units to be completely assembled and factory tested for quality assurance prior to shipment.
- 2.1.6. Curb Cap required for curb mounting on roof.
- 2.1.7. Fan to be UL-793 Listed for Power Ventilation for Smoke Control Systems including with snow load.
- 2.1.8. In the event of electrical failure, 165 degree F fusible link will activate spring assisted dampers to open to provide gravity ventilation.
- 2.1.9. Electrical service to this unit to separate from building service in accordance with codes.

2.2. CONSTRUCTION

- 2.2.1. Fan Tube shall be heavy gauge, G-90 galvanized steel for 24" through 54" (10hp); 60" shall be Carbon Steel primed and finished in grey epoxy paint. Tubes to be welded one-piece construction with 2" flanged ends for maximum strength. Up-blast wind band to be heavy gauge galvanized steel with Dampers of steel construction unless otherwise specified. Bronze bushings to be provided for galvanized steel damper shaft to rotate freely. Galvanized rain channel to be provided to drain water from damper.
- 2.2.2. Bearing Plate shall be a minimum 10ga, G-90 galvanize steel, welded in place and protected from the airstream by welded heavy ga steel sheet metal enclosure.
- 2.2.3. Propeller to high strength heavy duty steel with steel Hub plate. Propellers to be statically and dynamically balanced at factory before shipping.
- 2.2.4. Motors, bearings and belts to be shielded from the airstream by a bolted sheet metal enclosure with fresh air cooling. Drive to be belt drive with motor sized 150% of drive horsepower. Double Groove belt fixed pitch sheave to be used through 10hp. (3 belt fixed pitch sheaves on 15hp motor). Drives to be adjusted with sliding motor base and use non-static oil resistant V-belts. Shafts to be keyed, turned, ground and polished steel with anti-rust component to resist corrosion. Motor to be open drip proof unless specified otherwise. Motors to be nationally recognized and locally serviced brand.
- 2.2.5. Bearings to be minimum 200,000 hour life design. Cast-iron self-aligning pillow blocks of the ball bearing type, double-sealed, pre-lubricated and have extended lube Lines to serviceable grease fittings.
- 2.2.6. Integral Lifting Lugs required.
- 2.2.7. All construction to be of ferrous material in airstream.

UB3700-HT High Temperature Upblast Fan Guide Specification cont.

- 2.3. **ACCESSORIES** (Select as required)
- 2.4. Motor to be High Efficiency (TEFC; Explosion-proof; Corrosion duty).
 - 2.5. Drive sheaves to be adjustable pitch design to allow performance adjustment.
 - 2.6. Safety guards to be provided at inlet and outlet of fan. ½" x 1" mesh galvanized steel screen.
 - 2.7. Pre-fabricated Roof Curbs to be constructed from heavy gauge steel, welded construction. Curb height to be ____" (8", 12", special ht) with 1 ½" treated wood nailer, flat roof. (pitched roof ___rise on ___run; double pitched roof ___rise on ___run.)
 - 2.8. Roof Curbs to have burglar bars installed of ____" diameter x ____centers in __ directions.
 - 2.9. Non-fused Disconnect to be provided in NEMA____ (1,3R,4,4X) enclosure.
 - 2.10. Fan to be epoxy coated finish.
- 3.1. **INSPECTION**
- 3.1.1. Examine fan prior to installation for any damage in shipping. Report it immediately.
 - 3.1.2. Examine Roof Curb prior to installation to ensure a true flat mounting condition. Make sure flat surface of curb is clear of debris to ensure proper adhesion of caulking material between vent and curb surface.
- 3.2. **INSTALLATION AND ERECTION**
- 3.2.1. Install UB3700-HT Belt Drive High Temperature Tube axial Propeller Up-blast Exhaust Fan and Accessories in conformance with approved drawings and Moffitt specifications.
 - 3.2.2. Any necessary hardware and caulking for ventilator shall be included with units.
 - 3.2.3. Any additional material to be provided by installing contractor.
- 3.3. **DAMAGED MATERIAL**
Repair or replace all damaged material.