

EcoStream Louvers

45° Adjustable Wall Louvers



MoffittCorp.com | (800) 474-3267
1351 13th Ave S. Suite 130
Jacksonville Beach, FL 32250



EcoStream 45° Wall Louver Table of Contents

EcoStream 45° Wall Louver Table of Contents	2
EcoStream 45° Louver Comparison	3
LV1045 Wall Louver Product Details.....	4
LV1045 - Fixed 45° Wall Louver - "J" Blade	5
LV1045 - Fixed 45° Wall Louvers Info Sheet.....	6
LV3045 Fixed Drainable 45° Wall Louver Product Details	7
LV3045-4 Fixed Drainable 45° Wall Louver - 4"	8
LV3045-4 Fixed Drainable 45° Wall Louver - 4"	9
LV3045-6 Fixed Drainable 45° Wall Louver - 6"	10
LV3045-6 Fixed Drainable 45° Wall Louver - 6"	11
LV6045 - Adjustable Drainable 45° Wall Louver Product Details.....	12
LV6045-4EA Adjustable Drainable 45° Wall Louver – 4"	13
LV6045-4EA Adjustable Drainable 45° Wall Louver – 4" Free Area Chart	14
LV6045-4EA Adjustable Drainable 45° Wall Louver – 4" Performance Data	15
LV6045-4EA Adjustable Drainable 45° Wall Louver – 6"	16
LV6035-6EA Adjustable Drainable 45° Wall Louver – 6" Free Area Chart	17
LV6035-6EA Adjustable Drainable 45° Wall Louver – 6" Performance	18
LV6035-6EA Adjustable Drainable 45° Wall Louver – 6" Pictures	19
LV1045 - Fixed 45° Louver Guide Specification	20
LV3045-4 Fixed Drainable Louver Guide Specification	21
LV3045-6 Fixed Drainable Louver Guide Specification	22
LV6035-4EA Adjustable Drainable 45° Louver – 4" Guide Specification	23
LV6035-6EA Adjustable Drainable 45° Louver – 6" Guide Specification	24

EcoStream 45° Louver Comparison

Moffitt produces three types of EcoStream 45° wall louvers. See below to learn more about the differences between the different models.

LV1045

- Fixed Blades
- 5" deep
- Max. Size: 72" wide x 96" high

LV3045

- Fixed Blades
- 4"-6" deep
- Drainable Blades
- Max. Size: 72" wide x 96" high (single panel)

LV6045

- 75% Free Area
- 7" deep
- Max size: 60" wide x 96" high single section; multiple louver sets can be bottled together up to 120" w x 84" h or 84" w x 120" h Frames 4"-6" deep
 - **NOTE:** *Factory assembled multi-section max: 108" w x 48" h, larger sizes are field assembled.*

LV1045 Wall Louver Product Details

PRODUCT DESCRIPTION

EcoStream 45° Wall Louvers are especially fabricated to meet the rigors of heavy industry. Moffitt louvers are designed to provide maximum free area with minimal pressure drop and water entrainment. These louvers have been successfully used in many industrial applications.

STANDARD FEATURES

- Frame: 4" deep channel, 18 ga. Galvanized steel
- Blades: "J" style, 18 ga. Galvanized steel, riveted to frame
- Screen: 3/4" mesh 19 ga. Galvanized
- Min. Size: 12" wide x 12" high
- Max. Size: 72" wide x 96" high
- Mullion Covers (outside only)
Mounting slips and fasteners

OPTIONAL FEATURES

- 1.5" Face Flange
- Materials:
 - Aluminum
 - Stainless Steel
- Screen:
 - Aluminum insect, 3/4" mesh
 - Expanded alum., 1/2" mesh
 - Stainless steel
- Finish:
 - Vinyl acrylic paint
 - Epoxy coating
- Mullion covers for multiple installations
- Mounting clips and fasteners

INDUSTRY APPLICATIONS

- | | | |
|-------------------|--------------------------|---------------------------|
| • Steel Plants | • General Manufacturing | • Pulp and Paper Plants |
| • Aluminum Plants | • Chemical Plants | • Gypsum Wallboard Plants |
| • Glass Plants | • Mine Processing Plants | • Plastics Plants |
| • Power Plants | • Warehouses | |

LV1045 - Fixed 45° Wall Louver - "J" Blade

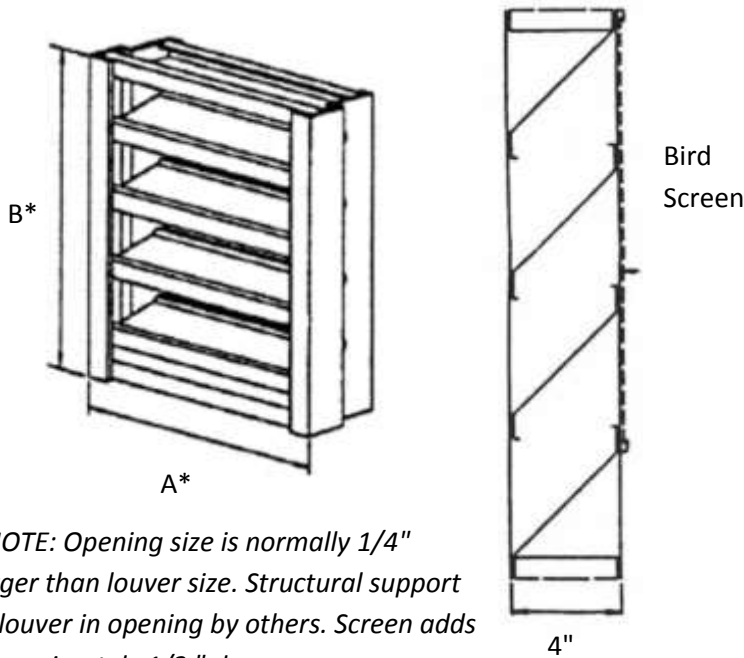

**NOTE: Opening size is normally 1/4" larger than louver size. Structural support of louver in opening by others. Screen adds approximately 1/2" deep*

Frame Construction

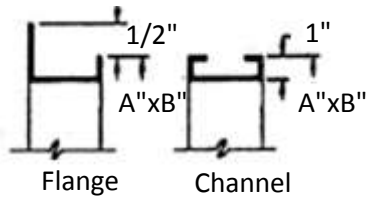

Standard Features

- Frame: 4" deep channel, 18 ga. Galvanized steel
- Blades: "J" style, 18 ga. Galvanized steel, riveted to frame
- Screen: 3/4" mesh 19 ga. Galvanized
- Min. Size: 12" wide x 12" high
- Max. Size: 72" wide x 96" high
- Mullion Covers (outside only)
- Mounting slips and fasteners

Optional Features

- Frame:
 - 6" Deep
 - 1 1/2" Face Flange
- Materials:
 - Aluminum
 - Stainless Steel
- Screen:
 - Aluminum insect, 3/4" mesh
 - Expanded alum., 1/2" mesh
 - Stainless steel
- Finish:
 - Vinyl acrylic paint
 - Epoxy coating
- Mullion covers for multiple installations
- Mounting clips and fasteners

Mark	QTY	Louver Size		Job Description
		A' Width	B' Height	



Moffitt Corporation certifies that the model shown herein is licensed to bear the AMCA seal. The ratings shown are based tests and procedures performed in accordance with AMCA Publication 211 and AMCA Publication 311 and comply with the requirements of the AMCA Certified Ratings Program.

All specifications are subject to change without notice unless approved in submittal by Moffitt Corporation, Inc.

LV1045 - Fixed 45° Wall Louvers Info Sheet

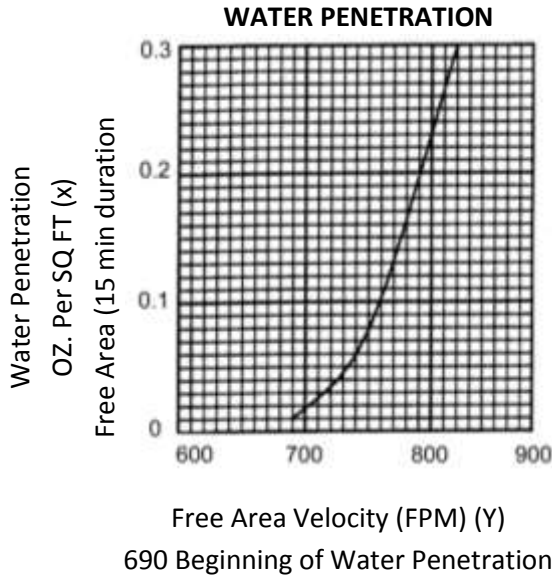

Louver Test
Size 48" x 48"

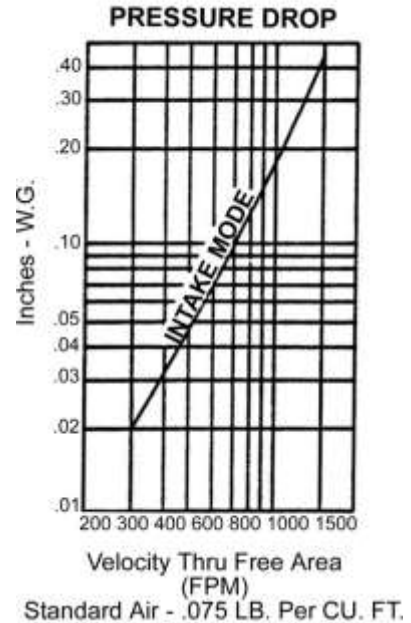

		Width (Inches)					
		12	24	36	48	60	72
Height	12	0.19	0.43	0.69	0.92	1.17	1.35
	24	0.67	1.53	2.37	3.25	4.14	4.89
	36	1.09	2.5	3.93	5.36	6.71	8.02
	48	1.52	3.51	5.45	7.51	9.42	11.19
	60	2.02	4.62	7.26	9.89	12.49	14.79
	72	2.4	5.49	8.52	11.60	14.90	17.61
	84	2.89	6.63	10.38	14.09	17.85	21.03
	96	3.32	7.54	11.89	16.02	20.51	24.28

Note: Ratings do not include the effect of bird screen

NOTE: To determine minimum free area required for the louver:

1. Divide the required CFM flow by the maximum recommended free area velocity.
2. From the free area table, select the most desirable louver size that meets the minimum free area requirement.

LV3045 Fixed Drainable 45° Wall Louver Product Details

PRODUCT DETAILS

EcoStream 45° Wall Louvers Wall Louvers are especially fabricated to meet the rigors of heavy industry. Moffitt louvers are designed to provide maximum free area with minimal pressure drop and water entrainment.

STANDARD FEATURES

- Fixed Louver Blades
- Drainable blades
- 45° blades
- Frames 4"-6" deep
- Min. Size: 12" × 12" (single panel)
- Max. Size: 72" × 96" (single panel)
- Galvanized Steel Construction, 18 ga.
- Mill finish
- Mullion Covers (outside only)
- Mounting Clips & Fasteners
- Galvanized bird screen

OPTIONAL FEATURES

- Materials:
 - Aluminum
 - Stainless Steel
- Seals:
 - Blade Seals
 - Stainless steel jamb seals
- Screen:
 - Aluminum insect, 3/4" mesh
 - Expanded alum., 1/2" mesh
 - Stainless steel
- Finish:
 - Vinyl acrylic paint
 - Epoxy coating
- Operator
 - Manual chain pull
 - hand crank
 - 115v motor
 - Hand wheel / Jack-shafting
- 1.5" Face Flange

APPLICATION

- | | | |
|-------------------|--------------------------|---------------------------|
| • Steel Plants | • General Manufacturing | • Pulp and Paper Plants |
| • Aluminum Plants | • Chemical Plants | • Gypsum Wallboard Plants |
| • Glass Plants | • Mine Processing Plants | • Plastics Plants |
| • Power Plants | • Warehouses | |

LV3045-4 Fixed Drainable 45° Wall Louver - 4"

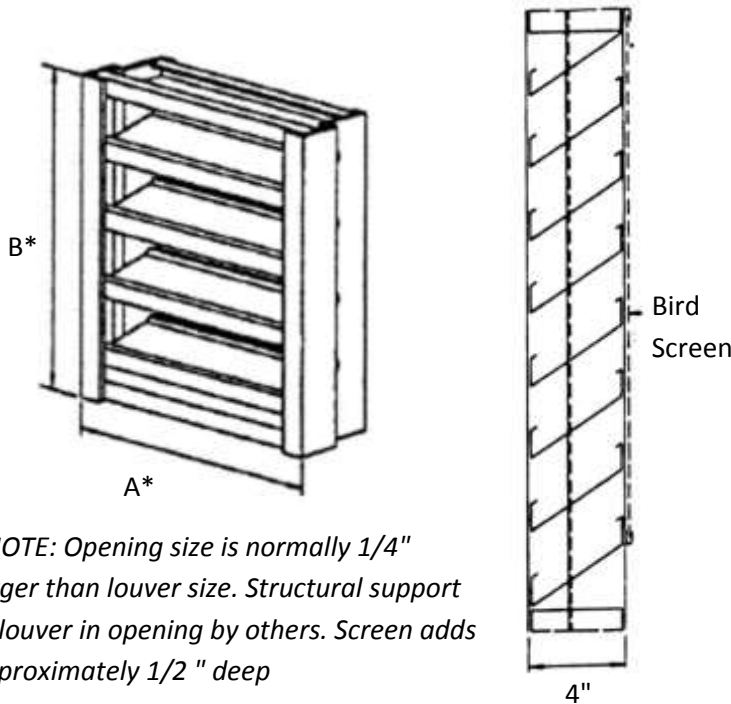

Standard Features

- Frame: 4" deep channel, 18 ga. Galvanized steel
- Blades: Drainable style, 18 ga. Galvanized steel, riveted to frame
- Screen: 3/4" mesh 20 ga. Galvanized
- Min. Size: 12" wide x 12" high
- Max. Size: 72" wide x 96" high
- Mullion Covers (outside only)
- Mounting slips and fasteners
- Galvanized bird screen

Optional Features

- Materials:
 - Aluminum
 - Stainless Steel
- Screen:
 - Aluminum insect, 3/4" mesh
 - Expanded alum., 1/2" mesh
 - Stainless steel
- Finish:
 - Paint to color match
 - Paint standard factory color
- Operator
 - Manual chain pull
 - hand crank
 - 115v motor
 - Hand wheel / Jack-shafting
- 1.5" Face Flange

Frame Construction

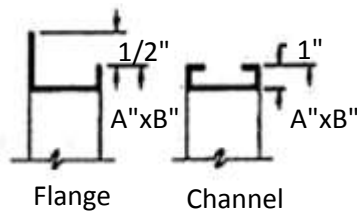

Mark	QTY	Louver Size		Job Description
		A' Width	B' Height	



Moffitt Corporation certifies that the model shown herein is licensed to bear the AMCA seal. The ratings shown are based tests and procedures performed in accordance with AMCA Publication 211 and AMCA Publication 311 and comply with the requirements of the AMCA Certified Ratings Program.

All specifications are subject to change without notice unless approved in submittal by Moffitt Corporation, Inc.

LV3045-4 Fixed Drainable 45° Wall Louver - 4"

Drainable Blade- 45°

Fixed blades are 6" deep fabricated louvers designed to give excellent protection against weather. Water cascading across louver face is greatly reduced because water is drained down the jamb channels and out over sill blade. Drainable blade design allows free area velocities to be higher than conventional blades. It is recommended that these velocities do not exceed 850 FPM.

Height (Inches)	Width (Inches)					
	12	24	36	48	60	72
12	0.27	0.61	0.98	1.36	1.67	2.04
24	0.53	1.33	2.13	2.91	3.70	4.40
36	0.97	2.39	3.80	5.20	6.63	7.83
48	1.34	3.27	5.20	7.12	9.07	10.75
60	1.67	4.09	6.51	8.94	11.37	13.50
72	2.03	5.12	8.14	11.2	14.21	16.88
84	2.31	5.83	9.28	12.74	16.22	19.27
96	2.70	6.82	10.86	14.95	19.01	22.53

Note: Ratings do not include the effect of bird screen

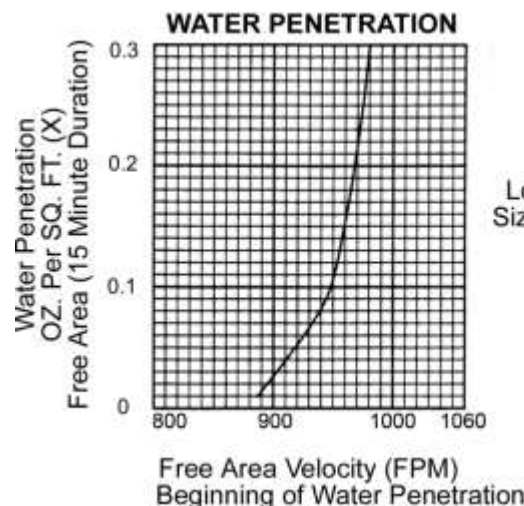
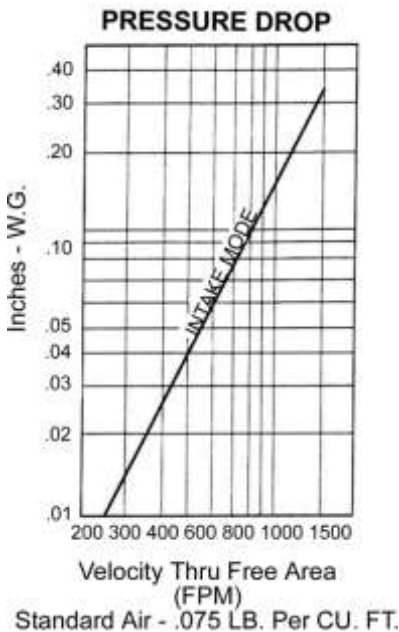

Standard Features

- Frame: 4" deep channel, 18 ga. Galvanized steel
- Blades: Drainable, 18 ga. Galvanized steel, riveted to frame
- Screen: 3/4" mesh 20 ga. Galvanized
- Min. Size: 12" wide x 12" high
- Max. Size: 72" wide x 96" high
- Mullion Covers (outside only)
- Mounting slips and fasteners
- Galvanized bird screen

Optional Features

- Materials:
 - Aluminum
 - Stainless Steel
- Screen:
 - Aluminum insect, 3/4" mesh
 - Expanded alum., 1/2" mesh
 - Stainless steel
- Finish:
 - Vinyl acrylic paint
 - epoxy coating
- Operator
 - Manual chain pull
 - hand crank
 - 115v motor
 - Hand wheel / Jack-shafting
- 1.5" Face Flange

LV3045-6 Fixed Drainable 45° Wall Louver - 6"

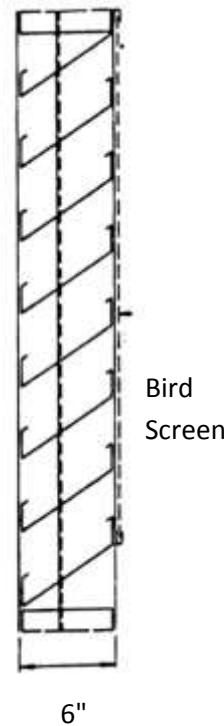
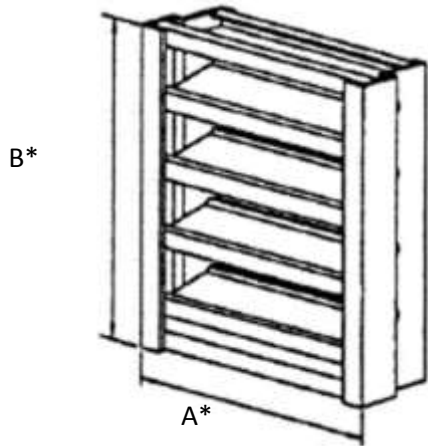

**NOTE: Opening size is normally 1/4" larger than louver size. Structural support of louver in opening by others. Screen adds approximately 1/2" deep*

Frame Construction

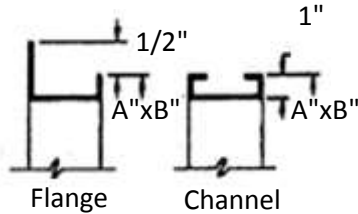

Standard Features

- Frame: 6" deep channel, 18 ga. Galvanized steel
- Blades: Drainable, 18 ga. Galvanized steel, riveted to frame
- Screen: 1/2" mesh 19 ga. Galvanized
- Min. Size: 12" wide x 12" high
- Max. Size: 72" wide x 96" high
- Mullion Covers (outside only)
- Mounting slips and fasteners

Optional Features

- Materials:
 - Aluminum
 - Stainless Steel
- Screen:
 - Aluminum Insect, 3/4" mesh
 - Expanded Aluminum
 - 1/2" mesh Stainless Steel
- Finish:
 - Vinyl acrylic paint
 - epoxy coating
- Operator
 - Manual chain pull
 - hand crank
 - 115v motor
 - Hand wheel / Jack-shafting
- 1.5" Face Flange

Mark	QTY	Louver Size		Job Description
		A' Width	B' Height	

All specifications are subject to change without notice unless approved in submittal by Moffitt Corporation, Inc.

LV3045-6 Fixed Drainable 45° Wall Louver - 6"

Drainable Blade- 45°

Fixed blades are 6" deep fabricated louvers designed to give excellent protection against weather. Water cascading across louver face is greatly reduced because water is drained down the jamb channels and out over sill blade. Drainable blade design allows free area velocities to be higher than conventional blades. It is recommended that these velocities do not exceed 850 FPM.

Height (Inches)	Width (Inches)					
	12	24	36	48	60	72
12	0.15	0.38	0.61	0.84	1.07	1.29
24	0.57	1.40	2.24	3.07	3.81	4.64
36	1.02	2.51	3.99	5.50	6.80	8.30
48	1.43	3.52	5.59	7.72	9.47	11.58
60	1.78	4.36	6.95	9.53	11.76	14.30
72	2.18	5.38	8.56	11.75	14.41	17.70
84	2.64	6.48	10.32	14.17	17.48	21.38
96	2.98	7.35	11.69	15.98	19.76	24.09

Note: Ratings do not include the effect of bird screen

Standard Features

- Frame: 6" deep channel, 18 ga. Galvanized steel
- Blades: Drainable, 18 ga. Galvanized steel, riveted to frame
- Screen: 1/2" mesh 19 ga. Galvanized
- Min. Size: 12" wide x 12" high
- Max. Size: 72" wide x 96" high
- Mullion Covers (outside only)
- Mounting slips and fasteners

Optional Features

- Materials:
 - Aluminum
 - Stainless Steel
- Screen:
 - Aluminum Insect, 3/4" mesh
 - Expanded Aluminum
 - 1/2" mesh Stainless Steel
- Finish:
 - Vinyl acrylic paint
 - epoxy coating
- Operator
 - Manual chain pull
 - hand crank
 - 115v motor
 - Hand wheel / Jack-shafting

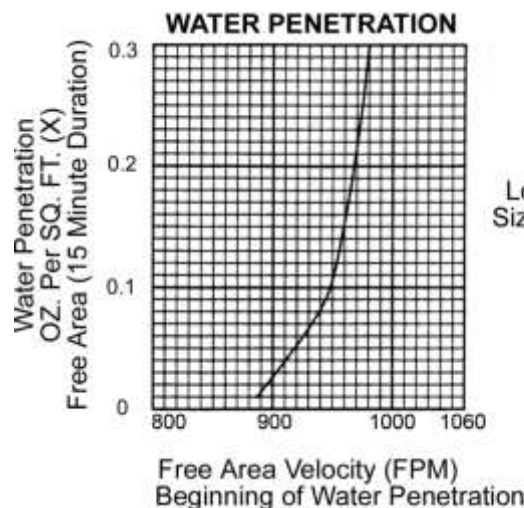
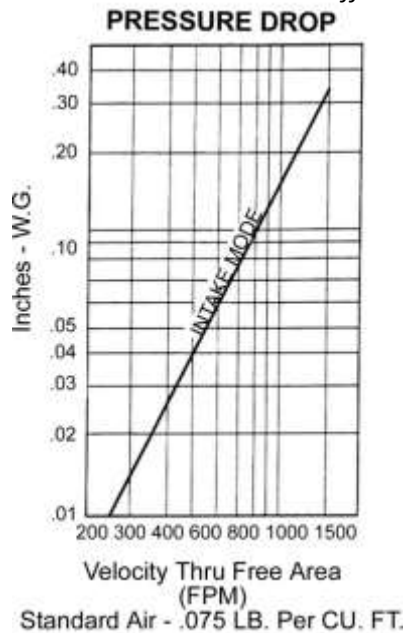

LV6045 - Adjustable Drainable 45° Wall Louver Product Details

PRODUCT DESCRIPTION

Moffitt EcoStream extruded aluminum adjustable drainable 45° Wall Louvers provide great performance, architectural appeal and adaptability to many design applications.

Moffitt extruded aluminum louvers are used in commercial and industrial applications in a variety of building industries. Combination style louvers with a fixed front blade and adjustable rear blade are also available in the extruded aluminum construction.

STANDARD FEATURES

- Adjustable Blades, Drainable
- 45° blade positioned on a 37° angle
- Min Size: 12" wide x 12" high
- Max size: 60" wide x 96" high single section; multiple louvers can be bottled together up to 120" w x 84" h or 84" w x 120" h Frames 4"-6" deep
 - **NOTE:** Factory assembled multi-section max: 108" w x 48" h, larger sizes are field assembled.
- .081" Extruded Aluminum Alloy Frame with Mill Finish
- Bird screen: 3/4" x .051" Flattened Aluminum in removable frame. Screen is mounted on inside (rear) as looking from exterior of building.
- Louvers without actuators will be supplied with locking quadrants
- Mounting Clips & Fasteners
- Integral jamb gutters and down spouts

OPTIONAL FEATURES

- Frame:
 - Flanged Frame
 - Extended Sill
 - Filter Racks
 - Security Bars
 - Hinged Sub frame
- Screen:
 - Insect (aluminum 18-16 Mesh)
- Finish:
 - Baked Powder Polyester
 - Baked Powder Fluoropolymer 70%
 - Baked Powder Clear Coat
 - Clear Anodize
 - Integral Color Anodize
- Operators
 - Manual chain pull
 - hand crank
 - 115v motor
 - Hand wheel
 - jack-shafting
- Seals
 - Blade Seals
 - Jamb seals
- 1.5" Face Flange

INDUSTRIAL APPLICATION

- | | | |
|-------------------|--------------------------|---------------------------|
| • Steel Plants | • General Manufacturing | • Pulp and Paper Plants |
| • Aluminum Plants | • Chemical Plants | • Gypsum Wallboard Plants |
| • Glass Plants | • Mine Processing Plants | • Plastics Plants |
| • Power Plants | • Warehouses | |

LV6045-4EA Adjustable Drainable 45° Wall Louver – 4” Drainable 4” Blade with Jamb Gutter Downspouts

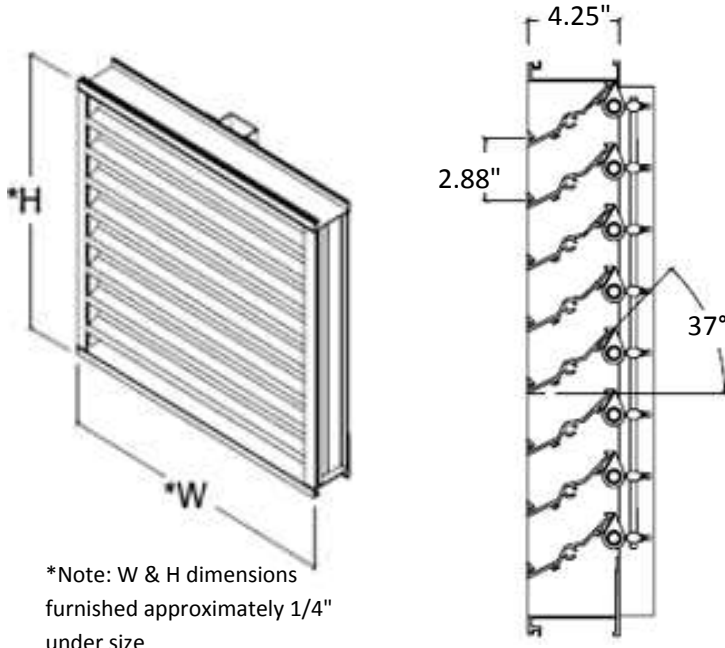

*Note: W & H dimensions furnished approximately 1/4" under size

Frame Construction

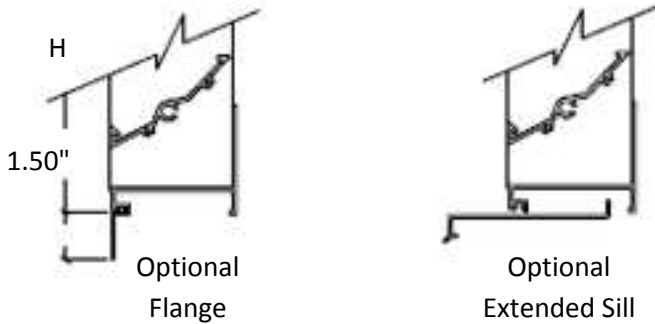

STANDARD FEATURES

- Adjustable Blades, Drainable
- 45° blade positioned on a 37° angle on approx. 2.88" centers
- Min Size: 12" wide x 12" high
- Max size: 60" wide x 96" high single section; multiple louvers can be bottled together up to 120" w x 84" h or 84" w x 120" h Frames 4"-6" deep
 - **NOTE:** Factory assembled multi-section max: 108" w x 48" h. Larger sizes are field assembled.
- .081" Extruded Aluminum Alloy Frame with Mill Finish
- Frame is 4.25" deep
- Bird screen: 3/4" x .051" Flattened Aluminum in removable frame. Screen is mounted on inside (rear) as looking from exterior of building.
- Louvers without actuators will be supplied with locking quadrants
- Mounting Clips & Fasteners
- Integral jamb gutters and down spouts

OPTIONAL FEATURES

- Frame:
 - Flanged Frame
 - Extended Sill
 - Filter Racks
 - Security Bars
 - Hinged Sub frame
- Screen:
 - Insect (aluminum 18-16 Mesh)
- Finish:
 - Baked Powder Polyester
 - Baked Powder Fluoropolymer 70%
 - Baked Powder Clear Coat
 - Clear Anodize
 - Integral Color Anodize
- Seals
 - Blade Seals
 - Jamb seals
- 1.5" Face Flange

Mark	QTY	Louver Size		Job Description
		A' Width	B' Height	

All specifications are subject to change without notice unless approved in submittal by Moffitt Corporation, Inc

LV6045-4EA Adjustable Drainable 45° Wall Louver – 4” Free Area Chart (square feet)

		Width (Inches)								
		12	18	24	30	36	42	48	54	60
Height (Inches)	12	0.27	0.44	0.60	0.77	0.94	1.10	1.28	1.45	1.61
	18	0.47	0.77	1.05	1.35	1.64	1.94	2.24	2.52	2.82
	24	0.68	1.11	1.53	1.96	2.38	2.81	3.23	3.66	4.08
	30	0.84	1.37	1.89	2.41	2.94	3.47	3.99	4.51	5.04
	36	1.03	1.67	2.32	2.96	3.60	4.24	4.89	5.53	6.17
	42	1.25	2.02	2.81	3.59	4.36	5.14	5.92	6.62	7.47
	48	1.44	2.34	3.23	4.13	5.02	5.92	6.81	7.71	8.61
	54	1.63	2.65	3.67	4.69	5.71	6.73	7.74	8.76	9.78
	60	1.84	2.98	4.12	5.26	6.40	7.55	8.69	9.83	10.97
	66	2.03	3.29	4.56	5.83	6.55	7.10	9.63	10.90	12.16
	72	2.24	3.62	5.02	6.41	7.80	9.19	10.58	11.98	13.37
	78	2.42	3.94	5.44	6.95	8.46	9.97	11.48	12.99	14.50
	84	2.64	4.59	5.93	7.57	9.22	10.86	12.51	14.17	15.82
90	2.84	4.61	6.38	8.14	9.91	11.69	13.45	15.22	16.97	
96	3.04	4.95	6.84	8.75	10.65	12.31	14.44	16.34	18.24	

LV6045-4EA Adjustable Drainable 45° Wall Louver – 4” Performance Data

High Performance Drainable Blade

Moffitt's LV6035-4EA is a weather louver designed to protect the outside opening in building exterior walls. These louvers may be used for exhaust or intake air. This model incorporates drainable blade and downspouts jamb gutter design for high performance.

Beginning point of WATER PENETRATION is 1119 fpm
the maximum recommended Free Area Velocity

Water Penetration

Standard Air- .075lb/ft³

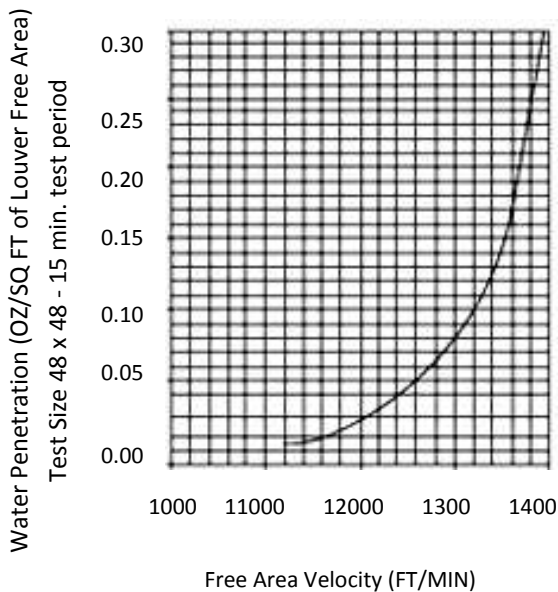

Pressure Drop

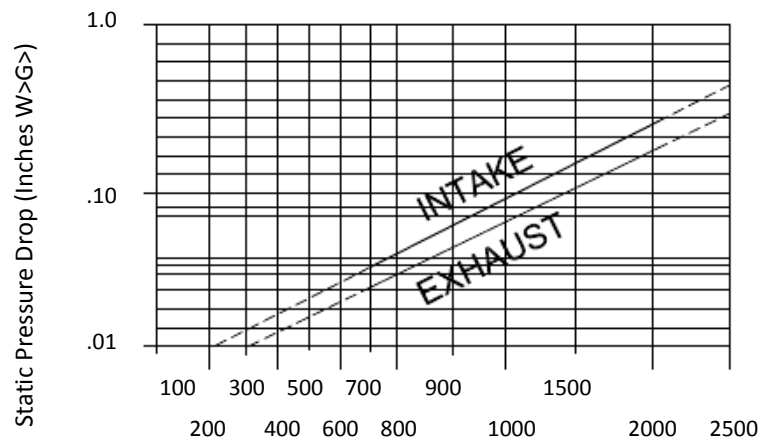

Test Size: 48" x 48"

Based on Standard Air- .075 lbs/ft³ - 15 min. duration

NOTE: Ratings do not include the effects of screen.



Moffitt Corporation certifies that the model shown herein is licensed to bear the AMCA seal. The ratings shown are based tests and procedures performed in accordance with AMCA Publication 211 and AMCA Publication 311 and comply with the requirements of the AMCA Certified Ratings Program.

All specifications are subject to change without notice unless approved in submittal by Moffitt Corporation

LV6045-4EA Adjustable Drainable 45° Wall Louver – 6”

Drainable 4" Blade with Jamb Gutter Downspouts

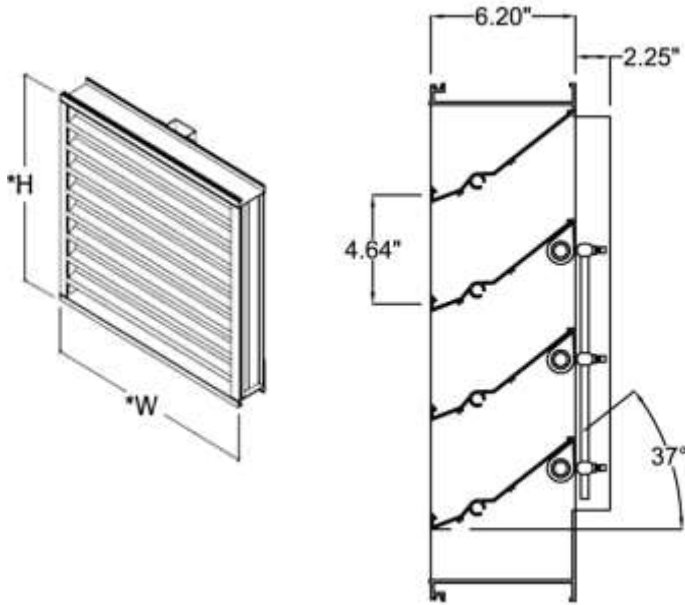

Frame Construction

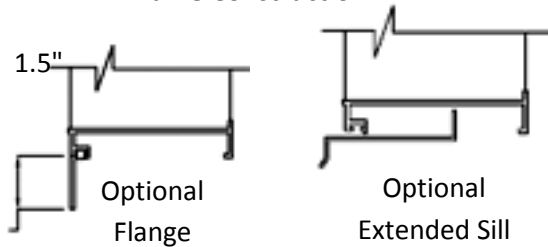

*Note: W & H dimensions furnished approximately 1/4" under size

Standard Features

- Adjustable Blades, Drainable
- 45° blade positioned Aluminum positioned on a 37° angle on approx. 4.64" centers
- .125" Extruded Aluminum Alloy Frame with Mill Finish
- Min Size: 12" wide x 12" high
- Max size: 60" wide x 96" high single section; multiple louvers can be bottled together up to 120" w x 84" h or 84" w x 120" h Frames 4"-6" deep
 - **NOTE:** Factory assembled multi-section max: 108" w x 48" h. Larger sizes are field assembled.
- Louvers without actuators will be supplied with locking quadrants
- Frame is 6.20" deep
- Bird screen: 3/4" x .051" Flattened Aluminum in removable frame, interior mounted screen.
- Mullion Covers
- Mounting Clips & Fasteners
- Integral jamb gutters and down spouts

Optional Features

- Frame:
 - Flanged Frame
 - Extended Sill
 - Filter Racks
 - Security Bars
 - Hinged Sub frame
- Screen:
 - Insect (aluminum 18-16 Mesh)
- Finish:
 - Baked Powder Polyester
 - Baked Powder Fluoropolymer 70%
 - Baked Powder Clear Coat
 - Clear Anodize
 - Integral Color Anodize
- Seals
 - Blade Seals
 - Jamb seals
- 1.5" Face Flange

Mark	QTY	Louver Size		Job Description
		A' Width	B' Height	

LV6035-6EA Adjustable Drainable 45° Wall Louver – 6" Free Area Chart

		Width (inches)								
		12	18	24	30	36	42	48	54	60
Height (inches)	12	12	18	24	30	36	42	48	54	60
	18	0.27	0.47	0.68	0.84	1.03	1.25	1.44	1.63	1.84
	24	0.44	0.77	1.11	1.37	1.67	2.02	2.34	2.65	2.98
	30	0.6	1.05	1.53	1.89	2.32	2.81	3.23	3.67	4.12
	36	0.77	1.35	1.96	2.41	2.96	3.59	4.13	4.69	5.26
	42	0.94	1.64	2.38	2.94	3.6	4.36	5.02	5.71	6.4
	48	1.1	1.94	2.81	3.47	4.24	5.14	5.92	6.73	7.55
	54	1.28	2.24	3.23	3.99	4.89	5.92	6.81	7.74	8.69
	60	1.45	2.52	3.66	4.51	5.53	6.62	7.71	8.76	9.83
	66	1.61	2.82	4.08	5.04	6.17	7.47	8.61	9.78	10.97
	72	12	18	24	30	36	42	48	54	60
	78	0.27	0.47	0.68	0.84	1.03	1.25	1.44	1.63	1.84
	84	0.44	0.77	1.11	1.37	1.67	2.02	2.34	2.65	2.98
	90	0.6	1.05	1.53	1.89	2.32	2.81	3.23	3.67	4.12
96	0.77	1.35	1.96	2.41	2.96	3.59	4.13	4.69	5.26	

LV6035-6EA Adjustable Drainable 45° Wall Louver – 6" Performance

High Performance Drainable Blade

Moffitt's LV6035-6EA is a weather louver designed to protect the outside opening in building exterior walls. These louvers may be used for exhaust or intake air. This model incorporates drainable blade and downspouts jamb gutter design for high performance.

Beginning point of WATER PENETRATION is 922 fpm
free area velocity at .01oz. of water penetration

Water Penetration

Standard Air- .075lb/ft³

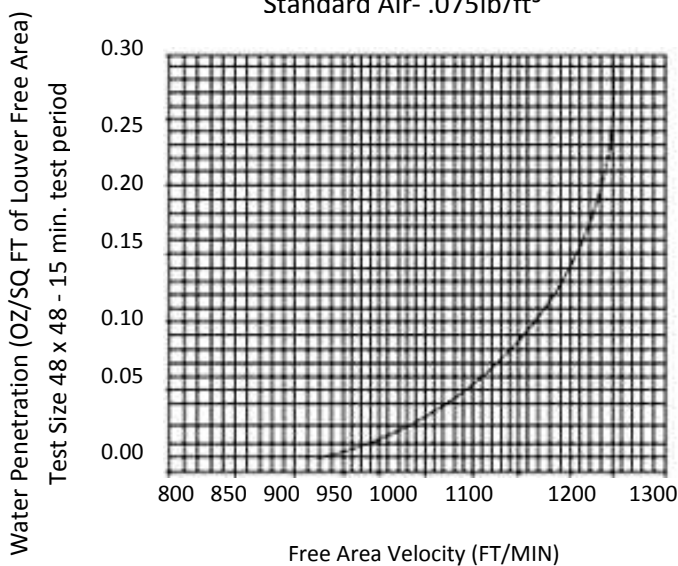

Pressure Drop

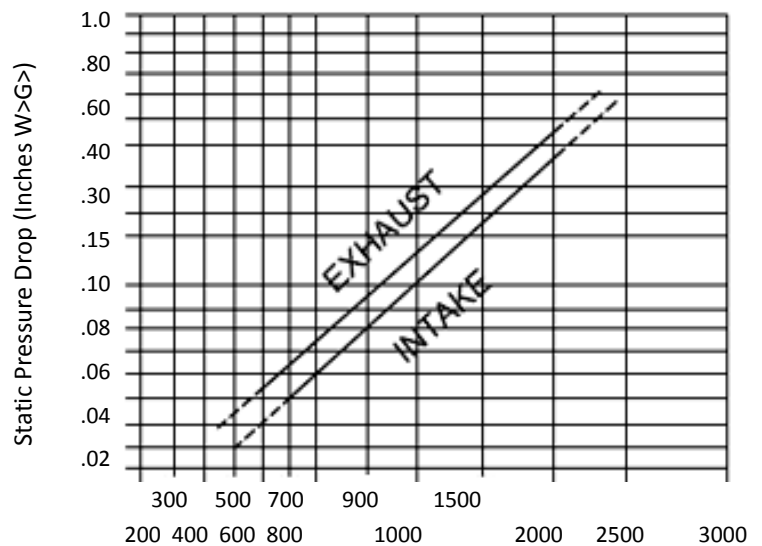

Test Size: 48" x 48"

Based on Standard Air- .075 lbs/ft³ - 15 min. duration

NOTE: Ratings do not include the effects of screen.



Moffitt Corporation certifies that the model shown herein is licensed to bear the AMCA seal. The ratings shown are based tests and procedures performed in accordance with AMCA Publication 211 and AMCA Publication 311 and comply with the requirements of the AMCA Certified Ratings Program

All specifications are subject to change without notice unless approved in submittal by Moffitt Corporation, Inc.

LV6035-6EA Adjustable Drainable 45° Wall Louver – 6" Pictures



LV1045 - Fixed 45° Louver Guide Specification

1.1. DESCRIPTION

Furnish and install LV1045-4 "J" Blade Fixed Aluminum Wall Louver with accessories as shown on the drawings.

1.2. QUALITY ASSURANCE

MOFFITT (Jacksonville, FL, 1-800-474-3267) Products establish the standard of quality required. Manufacturer and erector shall demonstrate a minimum of five (5) years of related industry experience.

1.3. SUBSTITUTIONS

No substitutions will be considered unless written request for approval has been submitted by the bidder and has been received by the designer at least ten (10) days prior to bid date. Any proposed substitutions should meet the standards set by the specification.

1.4. SUBMITTALS

Furnish approval drawings prior to fabrication and erection drawings prior to shipment showing all erection procedures and accessories required for the specified product.

2.1. DESIGN

The LV1045-4 Fixed Wall Louver shall be designed to withstand (20psf) ____psf wind load. The installer shall provide structural support as required to meet wind load. Blade style to be "J" style. The louver free area, water penetration and pressure drop levels shall meet or exceed those of the specified louver. The maximum louver assembled panel shall be 72" wide x 96" high for single section. Larger sizes to be field assembled. Frame to be channel frame design.

2.2. MATERIALS

The LV1045-4 Fixed Wall Louver frame shall be fabricated from 18ga galvanized steel material x 4" deep. Blades shall be 18ga galvanized steel material positioned at 45° angle and approximately 4" on centers. Louver to be mill finish and factory assembled.

2.3. ACCESSORIES (Select as required)

2.3.1. The louvers shall be equipped with ¾" mesh x 20ga galvanized (Aluminum, Stainless Steel) bird screen in a removable frame and installed on the rear (inside) of the louver.

2.3.2. Louver to have Flanged Frame.

2.3.3. Louvers to have Insect Screen – 18-16 Mesh Aluminum

2.3.4. Louvers to have Baked Powder Polyester Coating to Match

3.1. INSPECTION

Examine alignment of structural steel prior to installation and do not proceed until structure is within tolerances established by AISC.

3.2. INSTALLATION AND ERECTION

Install LV1045-4 Fixed Wall Louver and accessories in conformance with approved drawings and Moffitt specifications.

3.3. DAMAGED MATERIAL

Repair or replace all damaged material.

LV3045-4 Fixed Drainable Louver Guide Specification

3.4. DESCRIPTION

Furnish and install LV3045-6 Fixed Drainable Wall Louver with accessories as shown on the drawings.

3.5. QUALITY ASSURANCE

MOFFITT (Jacksonville, FL, 1-800-474-3267) Products establish the standard of quality required. Manufacturer and erector shall demonstrate a minimum of five (5) years of related industry experience.

3.6. SUBSTITUTIONS

No substitutions will be considered unless written request for approval has been submitted by the bidder and has been received by the designer at least ten (10) days prior to bid date. Any proposed substitutions should meet the standards set by the specification.

3.7. SUBMITTALS

Furnish approval drawings prior to fabrication and erection drawings prior to shipment showing all erection procedures and accessories required for the specified product.

4.1. DESIGN

The LV3045-6 Fixed Drainable Wall Louver shall be designed to withstand (20psf) _____ wind load. The installer shall provide structural support as required to meet wind load. Blade style to be drainable fixed style. The louver free area, water penetration and pressure drop levels shall meet or exceed those of the specified louver. The maximum louver assembled panel shall be 72" wide x 96" high for single section. Larger sizes to be field assembled. Frame is to be channel frame design.

4.2. MATERIALS

The LV3045-6 Fixed Drainable Wall Louver frame shall be fabricated from 18 ga galvanized steel material x 6" deep. Blades shall be 18 ga galvanized steel material positioned at 45° angle and approximately 6" centers. Louvers to be mill finish and factory assembled.

4.3. ACCESSORIES (Select as required)

4.3.1. The louvers shall be equipped with ¼" mesh x 20ga Galvanized Steel, (or Aluminum, or Stainless Steel) Bird screen in a removable frame and installed on the rear (inside) of the louver.

4.3.2. Louver to have Flanged Frame.

4.3.3. Louvers to have Insect Screen – 18-16 Mesh Aluminum

4.3.4. Louvers to have Baked Powder Polyester Coating to Match

5.1. INSPECTION

Examine alignment of structural steel prior to installation and do not proceed until structure is within tolerances established by AISC.

5.2. INSTALLATION AND ERECTION

Install LV3045-6 Fixed Drainable Wall Louvers and accessories in conformance with approved drawings and MOFFITT specifications.

5.3. DAMAGED MATERIAL

Repair or replace all damaged material.

LV3045-6 Fixed Drainable Louver Guide Specification

1.1. DESCRIPTION

Furnish and install LV3045-6 Fixed Drainable Wall Louver with accessories as shown on the drawings.

1.2. QUALITY ASSURANCE

MOFFITT (Jacksonville, FL, 1-800-474-3267) Products establish the standard of quality required. Manufacturer and erector shall demonstrate a minimum of five (5) years of related industry experience.

1.3. SUBSTITUTIONS

No substitutions will be considered unless written request for approval has been submitted by the bidder and has been received by the designer at least ten (10) days prior to bid date. Any proposed substitutions should meet the standards set by the specification.

1.4. SUBMITTALS

Furnish approval drawings prior to fabrication and erection drawings prior to shipment showing all erection procedures and accessories required for the specified product.

2.1. DESIGN

The LV3045-6 Fixed Drainable Wall Louver shall be designed to withstand (20psf)_____ wind load. The installer shall provide structural support as required to meet wind load. Blade style to be drainable fixed style. The louver free area, water penetration and pressure drop levels shall meet or exceed those of the specified louver. The maximum louver assembled panel shall be 72"wide x 96"high for single section. Larger sizes to be field assembled. Frame is to be channel frame design.

2.2. MATERIALS

The LV3045-6 Fixed Drainable Wall Louver frame shall be fabricated from 18 ga galvanized steel material x 6" deep. Blades shall be 18 ga galvanized steel material positioned at 45 degree angle and approximately 6" centers. Louvers to be mill finish and factory assembled.

2.3. ACCESSORIES (Select as required)

- 2.3.1. The louvers shall be equipped with ¾" mesh x 20ga Galvanized Steel (or Aluminum, or Stainless Steel) Bird screen in a removable frame and installed on the rear (inside) of the louver.
- 2.3.2. Louver to have Flanged Frame.
- 2.3.3. Louvers to have Insect Screen – 18-16 Mesh Aluminum
- 2.3.4. Louvers to have Baked Powder Polyester Coating to Match

3.1. INSPECTION

Examine alignment of structural steel prior to installation and do not proceed until structure is within tolerances established by AISC.

3.2. INSTALLATION AND ERECTION

Install LV3045-6 Fixed Drainable Wall Louvers and accessories in conformance with approved drawings and MOFFITT specifications.

3.3. DAMAGED MATERIAL

Repair or replace all damaged material

LV6035-4EA Adjustable Drainable 45° Louver – 4” Guide Specification

1.1. DESCRIPTION

Furnish and install LV6035-4EA Stationary Aluminum Drainable Wall Louver with accessories as shown on the drawings.

1.2. QUALITY ASSURANCE

MOFFITT (Jacksonville, FL, 1-800-474-3267) Products establish the standard of quality required. Manufacturer and erector shall demonstrate a minimum of five (5) years of related industry experience.

1.3. SUBSTITUTIONS

No substitutions will be considered unless written request for approval has been submitted by the bidder and has been received by the designer at least ten (10) days prior to bid date. Any proposed substitutions should meet the standards set by the specification.

1.4. SUBMITTALS

Furnish approval drawings prior to fabrication and erection drawings prior to shipment showing all erection procedures and accessories required for the specified product.

2.1. DESIGN

The LV6035-4EA Adjustable Aluminum Drainable Wall Louver shall be designed to withstand (20psf) ___psf. wind load. The installer shall provide structural support as required to meet wind load. Blade style to be drainable adjustable style. The louver free area, water penetration and pressure drop levels shall meet or exceed those of the specified louver. The maximum louver assembled panel shall be 120” wide x 84” or 84” x 120” high or 60” x 72” for single section. Larger sizes to be field assembled. Frame to be channel frame design.

2.2. MATERIALS

The LV6035-4EA Adjustable Aluminum Drainable Wall Louver frame shall be fabricated from .081” Extruded Aluminum material x 4.16” deep. Blades shall be .081” Extruded Aluminum material positioned at 37 degree angle and approximately 2.88” on centers. Louver to be mill finish and factory assembled.

2.3. ACCESSORIES (Select as required)

The louvers shall be equipped with ¾” mesh x .051” flattened aluminum bird screen in a removable frame installed on the rear (inside) of the louver.

2.3.1. Louver to have Flanged Frame.

2.3.2. Louver to have Extended Sill.

2.3.3. Louver to have Blade Seals.

2.3.4. Louver to have Jamb Seals.

2.3.5. Louvers to have Filter Frames for _____” Filters.

2.3.6. Louvers to have Security Bars. _____” x _____” on _____” centers.

2.3.7. Louvers to have Hinged Sub-frame

2.3.8. Louvers to have Insect Screen – 18-16 Mesh

2.3.9. Louvers to have Baked Powder Polyester Coating

2.3.10. Louvers to have Baked Powder Fluoropolymer Coating

2.3.11. Louvers to have Baked Powder Clear Coat

2.3.12. Louvers to be Clear Anodized

2.3.13. Louvers to be Integral Color Anodized.

3.1. INSPECTION

Examine alignment of structural steel prior to installation and do not proceed until structure is within tolerances established by AISC.

3.2. INSTALLATION AND ERECTION

Install LV6035-4EA Stationary Aluminum Wall Louver and accessories in conformance with approved drawings and MOFFITT specifications.

3.3. DAMAGED MATERIAL

Repair or replace all damaged material.

LV6035-6EA Adjustable Drainable 45° Louver – 6” Guide Specification

1.1. DESCRIPTION

Furnish and install LV6035-6EA Stationary Aluminum Drainable Wall Louver with accessories as shown on the drawings.

1.2. QUALITY ASSURANCE

MOFFITT (Jacksonville, FL, 1-800-474-3267) Products establish the standard of quality required. Manufacturer and erector shall demonstrate a minimum of five (5) years of related industry experience.

1.3. SUBSTITUTIONS

No substitutions will be considered unless written request for approval has been submitted by the bidder and has been received by the designer at least ten (10) days prior to bid date. Any proposed substitutions should meet the standards set by the specification.

1.4. SUBMITTALS

Furnish approval drawings prior to fabrication and erection drawings prior to shipment showing all erection procedures and accessories required for the specified product.

2.1. DESIGN

The LV6035-6EA Adjustable Aluminum Drainable Wall Louver shall be designed to withstand (20psf) ___psf. wind load. The installer shall provide structural support as required to meet wind load. Blade style to be drainable adjustable style. The louver free area, water penetration and pressure drop levels shall meet or exceed those of the specified louver. The maximum louver assembled panel shall be 120” wide x 120” for single section. Larger sizes to be field assembled. Frame to be channel frame design.

2.2. MATERIALS

The LV6035-6EA Adjustable Aluminum Drainable Wall Louver frame shall be fabricated from .125” Extruded Aluminum material x 6.20” deep. Blades shall be .081” Extruded Aluminum material positioned at 37° angle and approximately 4.64” on centers. Louver to be mill finish and factory assembled.

2.3. ACCESSORIES (Select as required)

The louvers shall be equipped with ¾” mesh x .051” flattened aluminum bird screen in a removable frame installed on the rear (inside) of the louver.

- 2.3.1. Louver to have Flanged Frame.
- 2.3.2. Louver to have Extended Sill.
- 2.3.3. Louver to have Blade Seals.
- 2.3.4. Louver to have Jamb Seals.
- 2.3.5. Louvers to have Filter Frames for _____” Filters.
- 2.3.6. Louvers to have Security Bars. _____” x _____” on _____” centers.
- 2.3.7. Louvers to have Hinged Sub-frame
- 2.3.8. Louvers to have Insect Screen – 18-16 Mesh
- 2.3.9. Louvers to have Baked Powder Polyester Coating
- 2.3.10. Louvers to have Baked Powder Fluoropolymer Coating
- 2.3.11. Louvers to have Baked Powder Clear Coat
- 2.3.12. Louvers to be Clear Anodized
- 2.3.13. Louvers to be Integral Color Anodized.

3.1. INSPECTION

Examine alignment of structural steel prior to installation and do not proceed until structure is within tolerances established by AISC.

3.2. INSTALLATION AND ERECTION

Install LV6035-6EA Stationary Aluminum Wall Louver and accessories in conformance with approved drawings and MOFFITT specifications.

3.3. DAMAGED MATERIAL

Repair or replace all damaged material.