

LightStream Natural Ventilation & Daylighting



MoffittCorp.com | (800) 474-3267
1351 13th Ave S. Suite 130
Jacksonville Beach, FL 32250



LightStream Table of Contents

LightStream Table of Contents	2
LightStream Product Details	3
LightStream Product Drawings – Hinge System.....	4
LightStream Product Drawings – Jamb & Mullion	5
LightStream Product Drawings – Mullion	6
LightStream Product Drawings – Hardware Options.....	7

LightStream Natural Ventilator

LightStream Product Details

PRODUCT DESCRIPTION

The LightStream is designed for everything from commercial to industrial applications. It provides cool, fresh air intake when mounted low and warm air exhaust when mounted higher up. When the unit is closed it provides ample daylighting through its large translucent panels.

An extruded aluminum framework houses light-permeating polycarbonate panels. A reliable operator, manual rack and pinion or motorized, allows for easy opening and closing, even with long unit runs. Each unit ships in factory assembled sections and is easily locked together in the field to form longer runs.

STANDARD FEATURES

- Aluminum Framework
- Light-permeating polycarbonate panels
- Reliable manual rack
- Operator - Manual or motorized
- Sections easily lock together to form longer runs
- Handles any temperature, commercial to industrial

PRODUCT FEATURES

- The LightStream can be mounted on the side wall at any elevation and utilized for either intake or exhaust
- Airflow performance modeled for optimal performance.

INDUSTRY APPLICATIONS

- | | | |
|-------------------------|---------------------|------------------------------|
| • Distribution | • Aluminum Industry | • Pulp & Paper Industry |
| • Storage Facilities | • Glass Industry | • Mine & Processing Industry |
| • General Manufacturing | • Power Stations | • Warehouse |
| • Steel Industry | • Chemical Industry | • + Other |



LightStream Natural Ventilator

LightStream Product Drawings - Hinge System

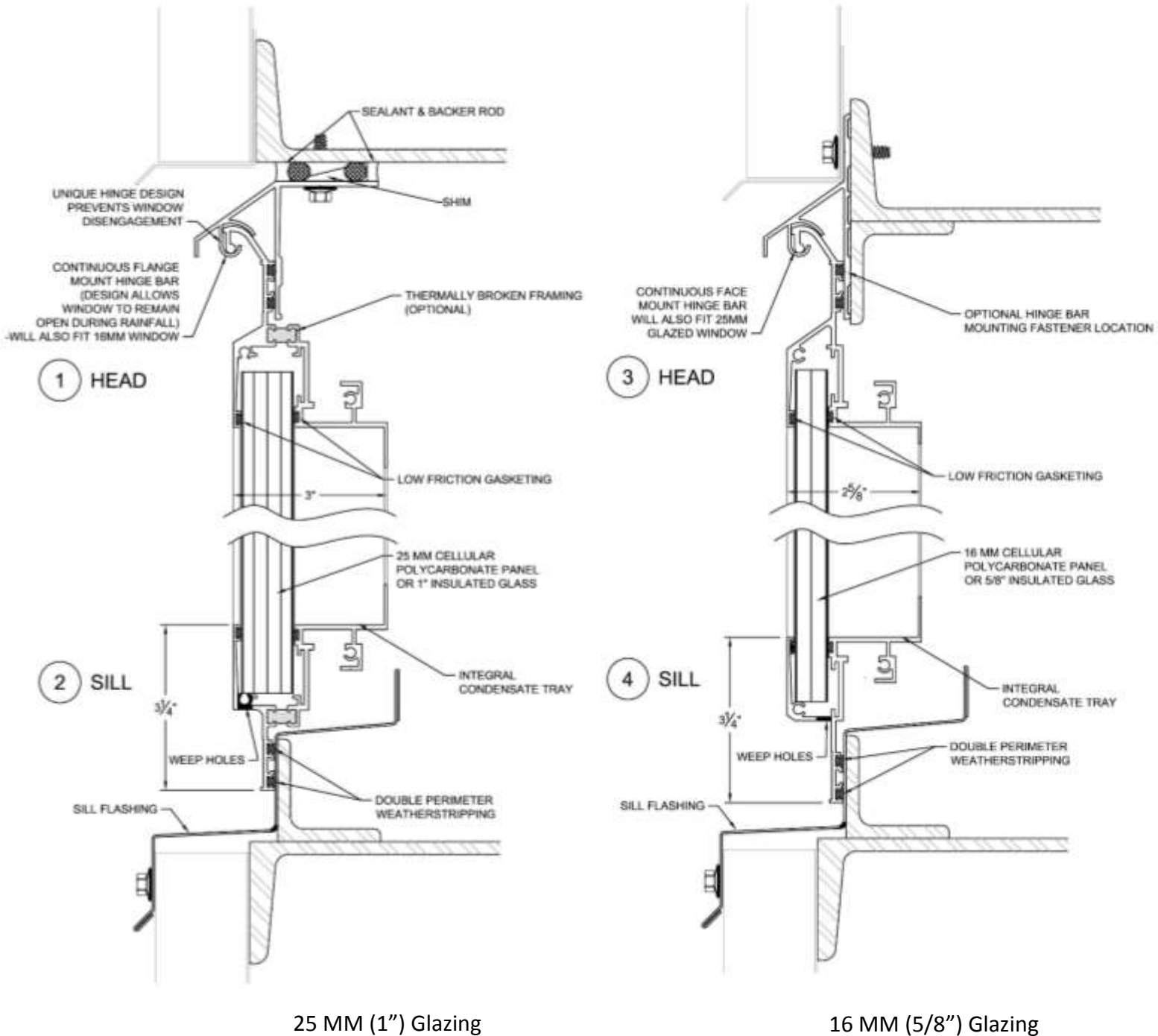

25 MM (1") Glazing

16 MM (5/8") Glazing

LightStream Product Drawings - Jamb & Mullion

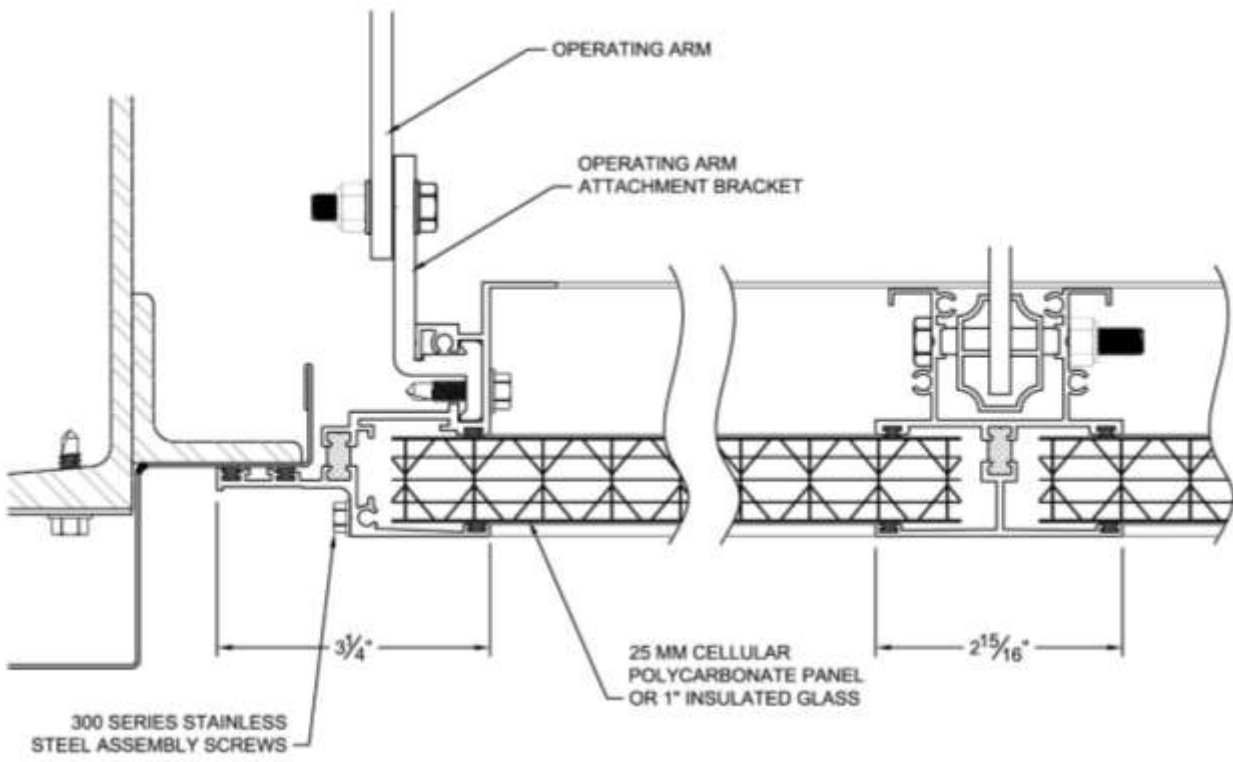

5 JAMB

6 MULLION

25MM (1") GLAZING

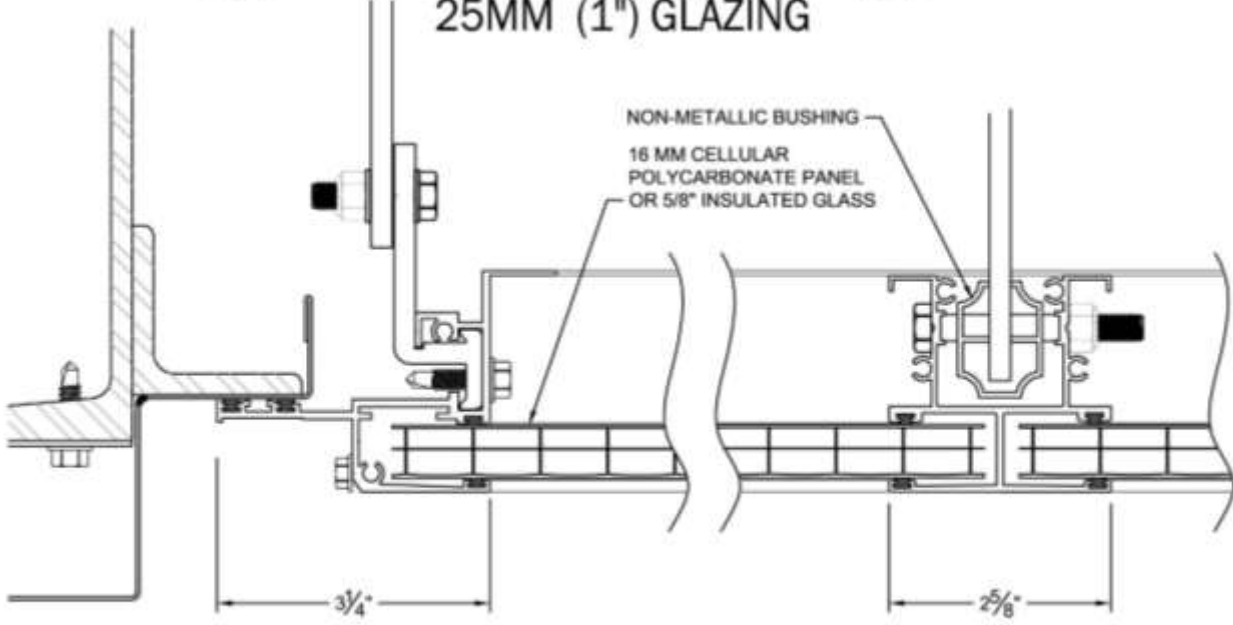

7 JAMB

8 MULLION

LightStream Product Drawings - Mullion

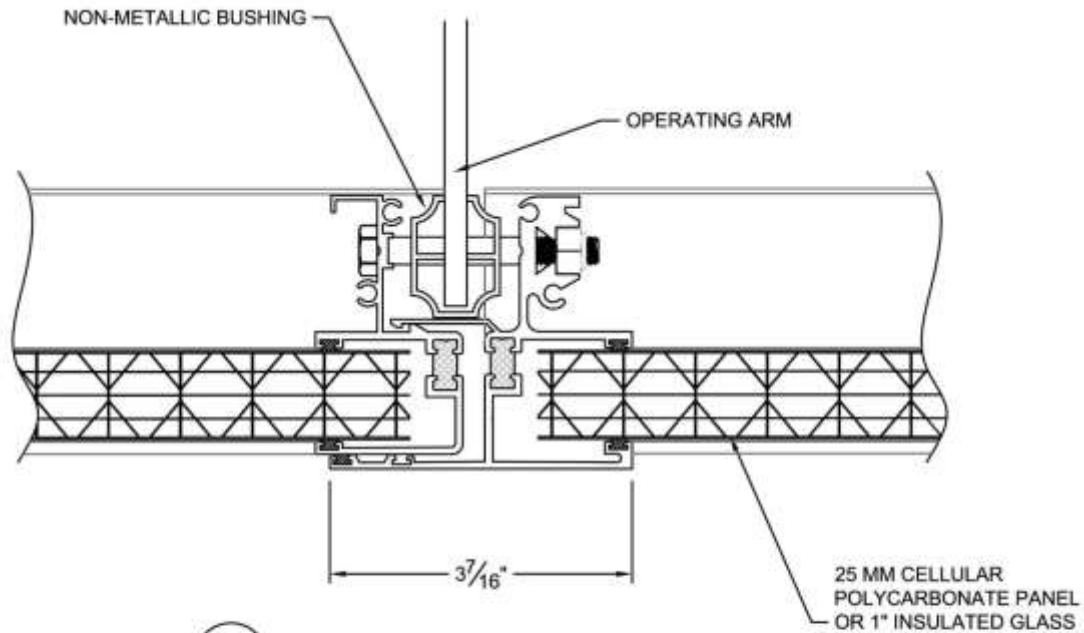

9 MALE / FEMALE MULLION
25MM (1") GLAZING

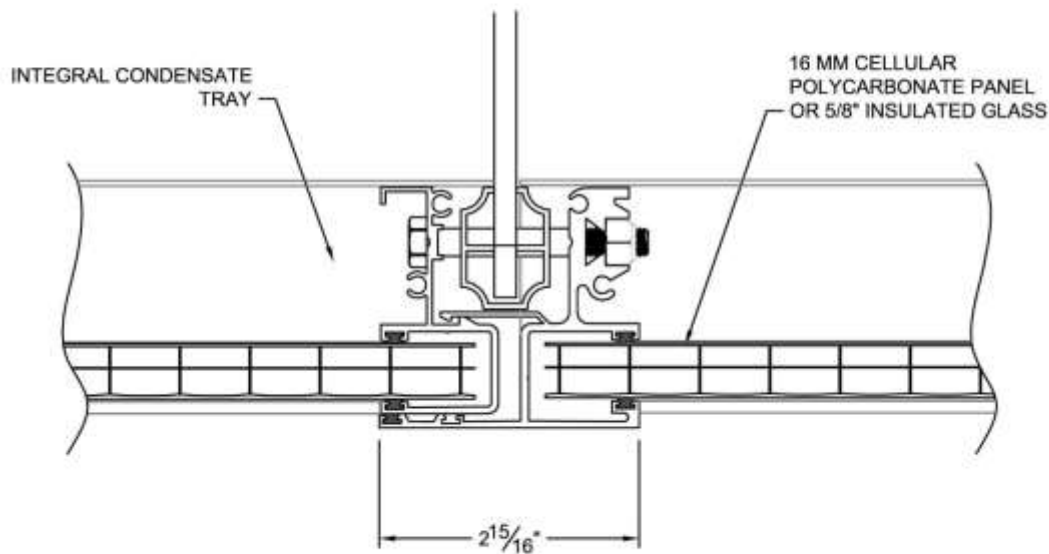

10 MALE / FEMALE MULLION
16MM (5/8") GLAZING

LightStream Natural Ventilator

LightStream Product Drawings - Hardware Options

RACK ARM

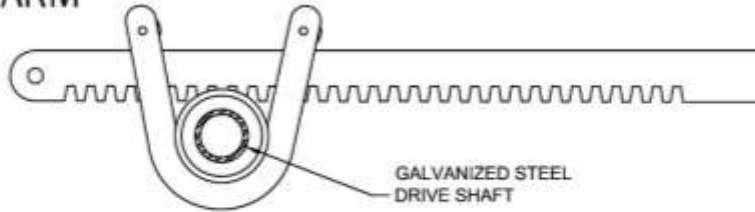

These are just some of the hardware options that are available for the LightStream system. Contact Moffitt for assistance in determining the best hardware package for your product.

ARTICULATED ARM

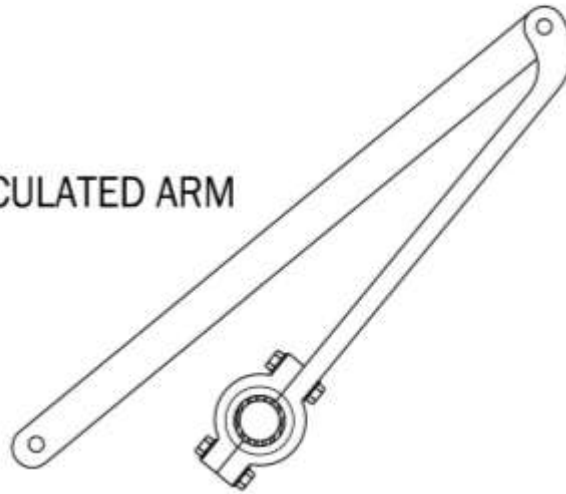

PUSH BAR

