

INSTALLATION INSTRUCTIONS FOR RIDGEPAC VENTILATORS - RP-9, RP-12

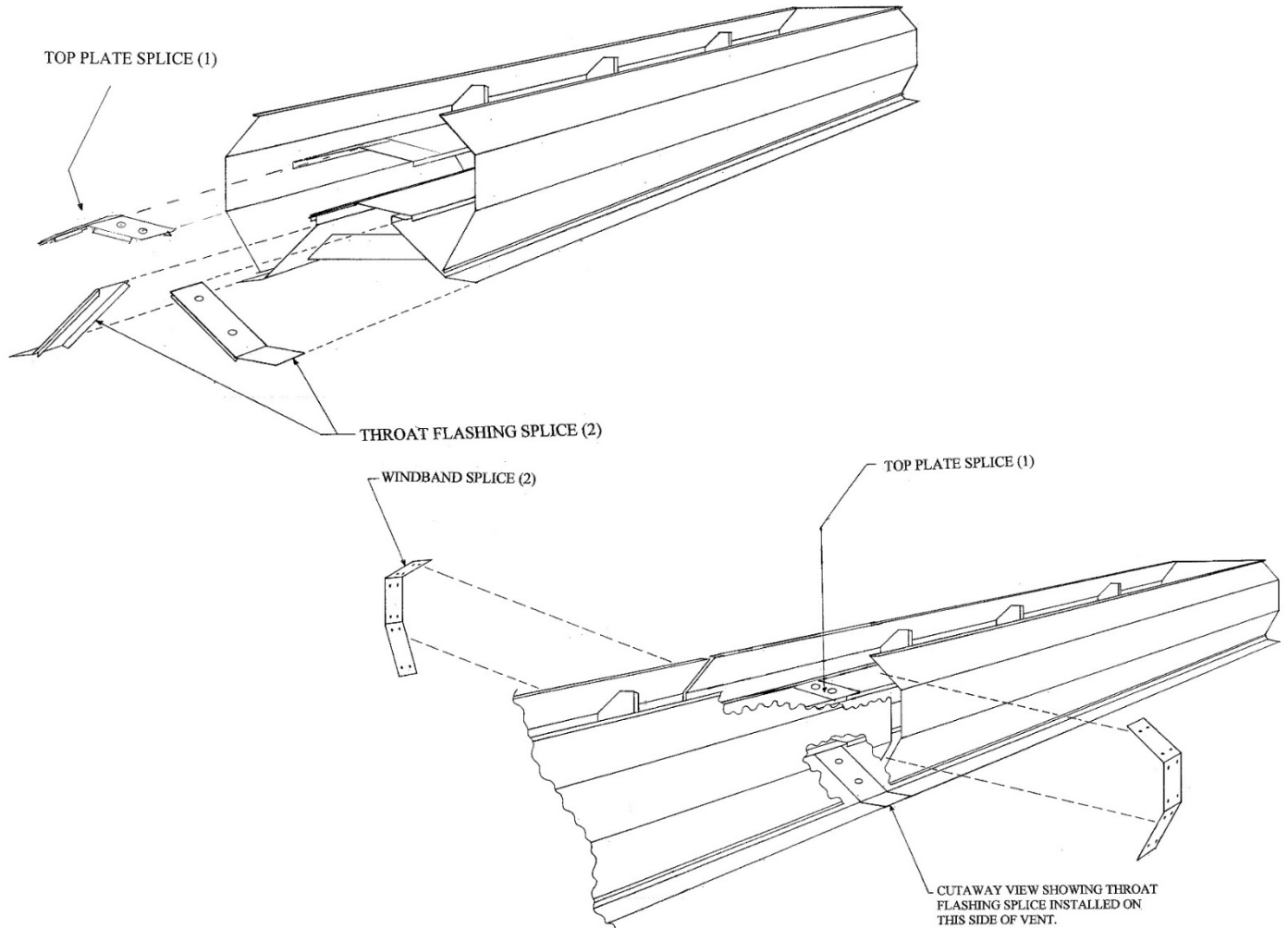

1. Uncrate units.
2. Set end unit "a" over roof opening.
3. Install (2) throat flashing splices and (1) top plate splice at open end of unit
4. Set an intermediate unit over roof opening, maintaining a 3/8" gap between units. Note: The units must be installed straight and true both vertically and horizontally along the length of the run.
5. Repeat steps 2, 3 and 4, for remainder of intermediate units.
6. Set end unit (end of run)
7. Install wind band splices, fasten with # 10 x 3/4" Tek screws.



INSTALLATION INSTRUCTIONS FOR RIDGEPAC VENTILATORS (WITHOUT DAMPER)

1. Uncrate units.
2. Set end unit "a" over roof opening.
3. Four (4) anchor straps are used to secure units to the building. Two (2) at each end throat gusset.
4. Install two (2) throat flashing splices at open end of unit see dwg. No. 0000-00.
5. Set an intermediate unit "b" over roof opening, maintaining a 3/8" gap.
6. Between units. See unit location plan dwg. No. 0000-00.
7. Note: the units must be installed straight & true both vertically and horizontally along the length of the run.
8. Repeat steps 2, 3 and 4, for remainder of intermediate "b" units.
9. Set end unit "c" (end of run).
10. Loosen screen at ends of each unit. (In order to access top plates).
11. Install top plate splices. Caulk between splice and top plate and fasten.
12. With # 10 x 3/4" Tek screws. See dwg. No. 0000-00.
13. Replace screen and splice together.
14. Install wind band splices, fasten with # 10 x 3/4" Tek screws.
15. See dwg. No. 0000-00.



INSTALLATION INSTRUCTIONS FOR RIDGEPAC VENTILATORS - RP-18, RP-15, RP-24

1. Set end operator unit on roof opening and fasten to roof. The anchor straps should be attached to the throat gussets prior to setting the units on the roof opening.
 - a. Units with 18" throat require four anchor straps, two at each end throat gusset.
 - b. Units with 24" throat require six anchor straps, two at each end throat gusset and two at the center throat gusset.
2. Loosen the screws at the damper filler plate on intermediate and end-added unit. Move the damper filler plate so that it extends beyond the end of the unit and retighten the screws. This fills the gap between the dampers when the units are assembled. *Make sure that the damper filler plate is under the dampers.*
3. Install two throat flashing splices at the open end of the unit.
4. Set intermediate unit on the roof opening, maintaining a 3/8" gap between units. The arrow on the unit should point towards the operator unit.
5. If intermediate operator units are required, see the unit location plan to determine their locations. Note: the units must be installed straight and true both vertically and horizontally along the length of the run to avoid binding of the operator bars.
6. Repeat steps 2, 3, and 4 for all intermediate units.
7. Set end added unit.
8. Install screens.
 - a. Loosen the screen at the ends of each unit.
 - b. Install top plate splice. Caulk between splice and top plate and fasten with #10 self-tapping screws.
 - c. Replace screen and splice ends together.
9. Install wind band splices with #10 self-tapping screws.
10. The balance of the installation will be done inside the building. Remove any shipping straps, tire wires or other obstructions to free operator bar movement.
11. With all dampers in the closed position, assemble the operator bar splices, adjust, and tighten the 1.1" lock nuts.

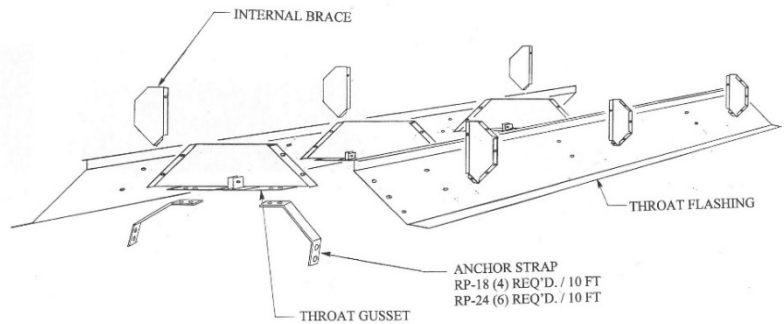
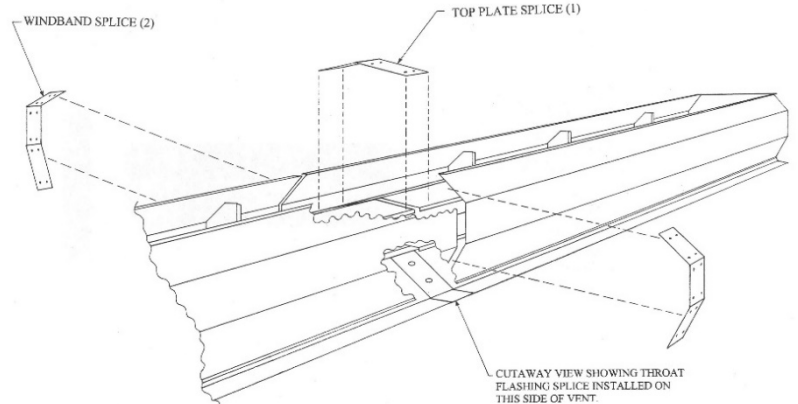
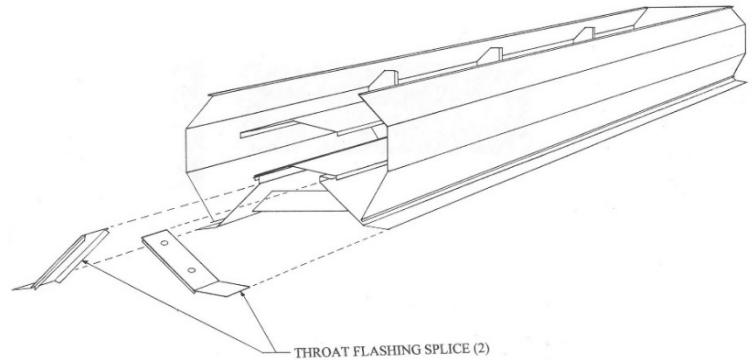

INSTALLATION INSTRUCTIONS FOR RIDGEPAC VENTILATORS (OPERATORS)

Installation varies depending on the type of operator. See below for operator installation instructions.

Manual winch operator

1. Install the winch and attach the cable per the winch manufacturer instructions.
2. If idler pulleys are used for cable direction change, install the Pulleys and thread the cable thru the pulley brackets.

Manual chain operator

1. Release the chain from the bottom of the operator unit.
2. If idler pulleys are used for chain direction change, mount the pulleys and thread the chain thru the pulley brackets.

Electric operator

1. The electric actuator is factory installed and requires no adjustment.
2. Motor manufacturer wiring diagram and Recommendations are included in the installation instructions.

Pneumatic operator

1. The pneumatic cylinder is factory installed and requires no adjustment.
2. Connect the air supply to the w' port in the cylinder. Use minimum w' pipe to provide maximum air volume to cylinder.
3. Line lubricators and filters are recommended in the air supply line.
4. The air requirement is 60-90 psi, depending on unit size and run length.

